



ENVIRONMENT AND SOCIAL MANAGEMENT PLAN

FOR THE

PROPOSED RENOVATION AND OPERATION OF OFFICE AND STAFF HOUSING AT BUDONGO CENTRAL FOREST RESERVE

Site points	Easting	Northing
West Waibira	337421	185153
Amaply site	354906	202122
Hanga site	354042	198903
Kabalye site	353838	190782
Biiso site	326055	192887
Siiba site	315374	183122
Katanga site	326977	178076
Nyakafunjo Beat	326897	178382

Consultant

INFRASTRUCTURE DEVELOPMENT AND MANAGEMENT LTD
PLOT 11-12 KAKUNGULU ROAD, NTINDA
P. O.BOX 27456, KAMPALA
TEL+256-772-407822
Email: infradev ltd2021@gmail.com

JANUARY 2025

CONSULTANCY TEAM DECLARATION OF INDEPENDENCE



NEMA CERTIFIED PRACTITIONERS		
<p>TEAM LEADER, MSC. ENVIRONMENT AND NATURAL RESOURCES, B. ENVIRONMENTAL MANAGEMENT EIA SPECIALIST AND REGISTERED PRACTITIONER</p> <p>CC/EIA/76/23</p>	<p>Josephine Auruga</p> 	
<p>TEAM MEMBER BSc. ENVIRONMENTAL ENGINEERING AND MANAGEMENT</p> <p>CC/EIA/268/23</p>	<p>Simon Peter Ssali</p> 	
CONTRIBUTING SPECIALISTS		
1.	Ms. Precious Kansime	Biodiversity Ecologist
2.	Mr. Kakaire Ibrahim	Environmental Engineer
3.	Mr. Ogolla John Martin	GIS and Pollution Specialist
4.	Ms. Nakayuka Prossy	Sociologist
5.	Ms. Ritah Kirabo Kamugungunu	Environmentalist (Waste management)
6.	Mr. Dickson Bigirwa	Forestry
7.	Mr. Aruho Moses	Environmentalist (Occupational Health and Safety)



TABLE OF CONTENTS

TABLE OF CONTENTS..... ii

LIST OF FIGURES..... vi

LIST OF TABLES vii

LIST OF ACRONYMS..... viii

1 INTRODUCTION 1

1.1 Background 1

1.2 Renovation objective 2

1.3 Objective of the ESMP 2

 1.3.1 Specific Objectives 2

2 PROJECT DESCRIPTION 4

2.1 Introduction 4

2.2 Project components..... 4

2.3 Renovation phase 36

 2.3.1 Construction inputs and equipment and the environment..... 37

 2.3.2 Project labour 37

 2.3.3 Utilities and Services 37

 2.3.3.1 Water supply, sewerage and storm water drainage 37

 2.3.3.2 Earthing and Lightning Protection 38

 2.3.3.3 Energy Sources 38

2.4 Operation Phase..... 38

 2.4.1 Fire and Emergency 38

 2.4.2 Energy Use and Supply..... 38

 2.4.3 Water and Sanitation 39

 2.4.4 Waste Management 40

2.4 Locations Description and Baseline 40

 2.4.1 West Waibira Staff Accommodation Renovation 40

 2.4.2 Amaply site 41

 2.4.3 Hanga site 42

 2.4.4 Kabalye site 43

 2.4.5 Biiso Renovation..... 44

 2.4.6 Siiba Renovation 45

 2.4.7 Katanga Renovation 46

 2.4.8 Nyakafunjo Beat 48

2.5 Biological Baseline description of Budongo CFR..... 51

 2.5.1 Flora 51

 2.5.1.1 Closed canopy forests..... 51

 2.5.1.2 Colonizing forests..... 51

 2.5.1.3 Mixed forest 51

2.5.1.4	Swamp and riverine forests.....	51
2.5.1.5	Savannah woodland and grassland	52
2.5.2	Fauna	52
2.6	Physical Characteristics of Budongo Central Forest Reserve.....	52
2.6.1	Climatic patterns.....	52
2.6.1.1	Rainfall patterns	52
2.6.2	Soils and Geology	52
2.7	Biophysical Characteristics of the Sites	53
2.7.1	Noise Assessment.....	53
2.7.2	Air Quality	54
2.7.3	Flora and Fauna	56
2.7.3.1	Nyakafunjo site	56
2.7.3.1.1	Conservation status of the recorded species	56
2.7.3.1.2	Protected tree species.....	56
2.7.3.2	Biiso	56
2.7.3.2.1	Conservation status of the recorded species	57
2.7.3.2.2	Protected tree species.....	57
2.7.3.3	West Waibira.....	57
2.7.3.3.1	Conservation status of the recorded species	57
2.7.3.3.2	Protected tree species.....	57
2.7.3.4	Amaply.....	58
2.7.3.4.1	Conservation status of the recorded species	58
2.7.3.4.2	Protected tree species.....	58
2.7.3.5	Hanga	58
2.7.3.5.1	Conservation status of the recorded species	59
2.7.3.5.2	Protected tree species.....	59
2.7.3.6	Kabalye Beat.....	59
2.7.3.6.1	Conservation status of the recorded species	59
2.7.3.6.2	Protected tree species.....	59
2.7.3.7	Siiba	59
2.7.3.7.1	Conservation status of the recorded species	60
2.7.3.7.2	Protected tree species.....	60
2.7.3.8	Katanga.....	60
2.7.4	Fauna	61
3	POLICY, LEGAL AND REGULATORY FRAMEWORK	62
3.1	National Policies	62
3.1.1	The National Environment Management Policy, 1994.....	62
3.1.2	The National Forestry Policy, 2001.....	62
3.1.3	Uganda Wildlife Policy, 2014.....	62
3.1.4	Uganda National Climate Change Policy, 2015.....	63

3.1.5	The National Land Use Policy, 2007	63
3.1.6	The National Gender Policy, 2007	64
3.1.7	The Child Labour Policy, 2006.....	64
3.1.8	Uganda Land Policy, 2013	65
3.2	Legal Framework.....	65
3.2.1	The Constitution of the Republic of Uganda, 1995	65
3.2.2	The National Environment Act Cap 181	66
3.2.3	The National Forestry and Tree Planting Act 2003.....	66
3.2.4	The Land Act, 1998	67
3.2.5	The Uganda Wildlife Act 2019	67
3.2.6	The National Climate Change Act, 2021	67
3.2.7	Employment Act, 2006	68
3.2.8	The Workers’ Compensation Act, 2000	69
3.2.9	The Water Act, Cap 152	69
3.2.10	The Occupational Safety and Health Act, 2006.....	69
3.3	Regulations and Standards.....	70
3.3.1	The National Environment (Waste Management) Regulations, 2020	70
3.3.2	National Environment (Environmental and Social Assessment Regulations), 2020	70
3.3.3	The National Forestry and Tree Planting Act, 2016.....	71
3.3.4	The <i>National Environment (Minimum Standards for Management of Soil Quality Regulations, 2001)</i>	71
3.3.5	The National Environment (Noise and Vibrations Standards and Control) Regulations, 2003.....	72
3.3.6	National Environment (Air Quality Standards) Regulations, 2024	73
3.4	International Treaties and Conventions	74
3.4.1	Convention on Biological Diversity, 1992	74
3.4.2	The United Nations Framework Convention on Climate Change (“1992 UNFCCC”).....	74
3.4.3	The 1968 African Convention on the Conservation of Nature and Natural Resources	75
3.5	Relevant Permits	75
3.6	World Bank Environmental and Social Standards	78
3.7	List of Plans to be Included in The Contractor’s C-ESMP	81
4	METHODOLOGY	82
4.1	Environmental and Social Screening	82
4.2	Document Review	82
4.3	Site Reconnaissance	82
4.4	Stakeholder Consultations.....	83
4.1.1	Engagement Activities	84

5	ANTICIPATED IMPACTS AND MITIGATION MEASURES	88
5.1	Positive impacts	88
5.1.1	Improved Living Conditions for Staff	88
5.1.2	Increased Productivity and Morale	88
5.1.3	Increased Health Benefits	89
5.1.4	Employment Opportunities	89
5.1.5	Market for Construction Materials.....	89
5.2	Negative Impacts.....	89
5.2.1	Construction Phase Impacts.....	89
5.2.1.1	Vegetation Loss	89
5.2.1.2	Soil and Geological Disturbances	90
5.2.1.3	Wildlife Disturbance	91
5.2.1.4	Deforestation.....	91
5.2.1.5	Noise.....	92
5.2.1.6	Poor Waste Management	92
5.2.1.7	Air and Dust Emission.....	93
5.2.1.8	Occupational Health and Safety Risks to Workers.....	94
5.2.1.2	Staff Safety Risks Associated with Renovation Activities.....	94
5.2.1.9	Sexual Harassment and Risks of HIV	95
5.2.2	Operation phase	96
5.2.2.1	Poor Waste management	96
5.2.2.2	Occupational Health and Safety risks and impacts.....	97
5.2.2.3	Visual impacts.....	97
6	ENVIRONMENTAL AND SOCIAL MANAGEMENT AND MONITORING PLAN	98
6.1	Monitoring team	98
6.1.1	EIA Unit	98
6.1.2	Project Coordination Unit (PCU).....	98
6.2	Grievance Management.....	99
7	CONCLUSION	112
	REFERENCES.....	113
	APPENDICES.....	114
	APPENDIX 1: CODES OF CONDUCT	114
	APPENDIX 2: CHANCE FINDS PROCEDURE.....	120

LIST OF FIGURES

Figure 2.1: West Waibira Site Layout 5

Figure 2.2: West Waibira Renovation drawings 7

Figure 2.3: Amaply site Renovation drawings 8

Figure 2.4: Hanga beat Site Layout..... 9

Figure 2.5: Hanga site Renovation drawings..... 13

Figure 2.6: Kabalye site Renovation drawings 19

Figure 2.7: Nyakafunjo site Renovation drawings 23

Figure 2.8: Biiso site Renovation drawings 27

Figure 2.9: Siiba site Renovation drawings 31

Figure 2.10: Katanga site Renovation drawings 36

Figure 2.11 West Waibira existing components 41

Figure 2.12: Amaply site existing components 42

Figure 2.13: Hanga site existing components 43

Figure 2.14: Kabalye site existing components 44

Figure 2.15: Biiso site expected components 45

Figure 2.16: Siiba site expected components..... 46

Figure 2.17: Katanga site expected components 47

Figure 2.18: Nyakafunjo beat existing components..... 48

Figure 2.19: Location of the proposed sites 49

Figure 2.20: Google view of the proposed sites 50

LIST OF TABLES

Table 2-1: Baseline Noise Results for Renovation Sites	53
Table 2-2: The Air quality Baseline Results for the renovation sites	55
Table 2: Maximum Permissible Noise Levels for Construction Site	72
Table 4: Regulatory Air Quality Standards for selected Pollutants	73
Table 5: Required permits	76
Table 3-4: World Bank Environmental and Social standards	78
Table 4-1: Stakeholders Consulted on the Project	83
Table 4-2: Summary of Key Issues Raised by Stakeholders.....	85
Table 6-1: Environmental Social Management and Monitoring Plan.....	100

LIST OF ACRONYMS

AIDS	Acquired Immune Deficiency Syndrome
AQG	Air Quality Guideline
AQI	Air Quality Index
Cap	Caption
CO	Carbon dioxide
NO _x	Nitrogen Oxides
SO ₂	Sulphur Dioxide
COVID-19	Corona Virus Disease
DIZ	Direct Impact Zone
EA	Environmental Assessment
EHS	Environmental, Health and Safety
EHS	Environment Health and Safety
EHSG	Environment Health and Social Safe Guards
EIA	Environmental Impact Assessment
ESIA	Environmental Social Impact Assessment
ESMP	Environmental and Social Management Plan
FGDs	Focus Group Discussions;
GBV	Gender Based Violence
GoU	Government of Uganda
GPS	Global Positioning System
H & S	Health and Safety
HIV	Human Immuno-deficiency Virus
hrs	hours
HSE	Health Safety and Environment
IIZ	Indirect Impact Zone
IPF	Investment Project Financing
IUCN	International Union for Conservation of Nature
IWRM	Integrated Water Resources Management

KII	Key Informant Interviews
LC	Local Council
LTD	Limited
MGLSD	Ministry of Gender Labour and Social Development
mi	mile
MLHUD	Ministry of Lands, Housing and Urban Development
mm	millimeter
MoU	Memorandum of Understanding
MoWE	Ministry of Water and Environment
NDP	National Development Plan
NEA	National Environment Act
NEMA	National Environment Management Authority
OSH	Occupational Safety and Health
PPEs	Personal Protective Equipment
PA	Protected Area
Sn	Serial number
STDs	Sexually-Transmitted Diseases
ToR	Terms of Reference
UAC	Uganda AIDs Commission
UGP	Uganda Gender Policy
VES	Visual Encounter Surveys
VIP	Ventilated Improved Pit
VOL	Volume
WCS	World Conservation Status
ZoI	Zone of Influence

1 INTRODUCTION

1.1 Background

The National Forest Authority (NFA) is an implementing arm under the Investing in Forests and Protected Areas for Climate-Smart Development Project (IFPA-CD Project), supported by financing from the World Bank. The primary goal of this initiative is to bolster forest and wildlife preservation for the betterment of local communities and the national economy. With the project's support, the NFA is spearheading various infrastructure endeavors across 13 specified protected regions. Budongo CFR has been selected as one of the recipients of the IFPA-CD project. To enhance infrastructure within the reserve, the NFA has contracted Infrastructure Development and Management Limited (IDML) to plan the renovation of the office and staff accommodation for Budongo CFR.

The main aim of the project is to renovate both the office and staff accommodation, ensuring efficient reserve management and visitor contentment. The project encompasses renovations across eight (8) sites: West Waibira, Amaply site, Hanga site, Kabalye site, Biiso site, Siiba site, Katanga site, and Nyakafunjo Beat.

At the Amaply site, the consultant has recommended a complete reconstruction of the system due to foundational instability. The foundation cannot support the structure, and as such, a full reconstruction is deemed necessary to ensure safety and long-term sustainability.

The specific project objectives include:

- Improving the on-site accommodation for field staff, so it provides decent housing for NFA.
- The comfort of the NFA field staff with their families at their workplaces, with inclusion of such features as, for example, water born toilets, ceiling, rain water harvesting systems will be installed under this project.

- Safety and compliance to ensuring that the renovated structure complies with building codes, safety regulations, and industry standards. This involves addressing any structural deficiencies.

1.2 Renovation objective

To enhance the functionality, aesthetics, and sustainability of the National Forestry Authority's staff accommodation and office spaces. Through thoughtful design and implementation, the goal is to create an environment that fosters productivity, comfort, and environmental responsibility.

1.3 Objective of the ESMP

The main objective of the environmental and social management plan is to identify document the environmental and social risks and impacts related to the proposed development and propose mitigation measures that will ensure that the project will be implemented sustainably.

1.3.1 Specific Objectives

- To study the baseline environmental and socio-economic conditions of the project area and its surroundings and to assess how these conditions will be affected by the proposed development.
- To identify relevant legislation and policy framework that needs to be complied with for the proposed project activities, and presentation of recommendations as to how they should be addressed under the proposed project.
- Carry out consultations with relevant stakeholders to obtain their views and suggestions regarding the environmental and social impacts
- To identify and assess the likely positive and negative environmental and social impacts of the proposed project and to recommend feasible measures to enhance positive impacts and mitigate the negative impacts.

- To prepare an Environmental and Social Management Plan (ESMP) that will guide the implementation and monitoring of the mitigation measures for the anticipated project risks.
- To describe the measures required to implement construction-related management and mitigation commitments made in the Environmental and Social Commitment Plan for the IFPA-CD project.
- To identify the roles and responsibilities of the environmental and social management organization of the project.
- To communicate environmental and social expectations and requirements throughout the project life cycle.

2 PROJECT DESCRIPTION

2.1 Introduction

The office building and staff accommodation renovation project aims to enhance the working and living conditions of NFA staff by creating a safe, comfortable, and visually appealing environment. This initiative addresses both immediate maintenance needs and comprehensive upgrades to ensure that the facilities meet modern safety and sustainability standards. Key objectives include establishing a healthy and efficient working environment through necessary repairs, improving the aesthetic appeal of the office and living spaces to foster a welcoming atmosphere, and incorporating sustainable practices to minimize environmental impact.

2.2 Project components

The project encompasses several critical components, starting with immediate maintenance works focusing on structural repairs. Renovations will take place at West Waibira, Amaply site, Hanga site, Kabalye site, Biiso site, Siiba site, Katanga site, and Nyakafunjo Beat. These works will address critical issues such as leaks, damaged roofing, and faulty plumbing, ensuring the safety and functionality of the facilities. Additionally, outdated electrical and plumbing systems will be replaced to improve efficiency and reliability. The full renovation works will upgrade common areas such as kitchens and bathrooms with modern fixtures, enhance energy efficiency through insulation improvements and energy-efficient appliances, and refresh interiors with new paint and refurbishments to create a pleasant and motivating workspace. The activities to be performed during the renovation for all the sites except Amaply include changing the roof, structural coverings, refurbishing the windows, doors and replacing defective ones, refining the dilapidated ceilings, new floor strides, reconstructing the aprons, repairing the walls by replacing defective plaster with new plaster, installing power supply and fittings, installing rainwater harvest system. For Amaply beat, reconstruction of the entire system is recommended. The foundation cannot support the structure and therefore, a complete reconstruction is recommended.

Effective project management is essential for the success of this renovation. A detailed project plan will be developed, outlining timelines, budgets, and resource allocation, while actively engaging employees in the planning process to understand their needs and preferences.

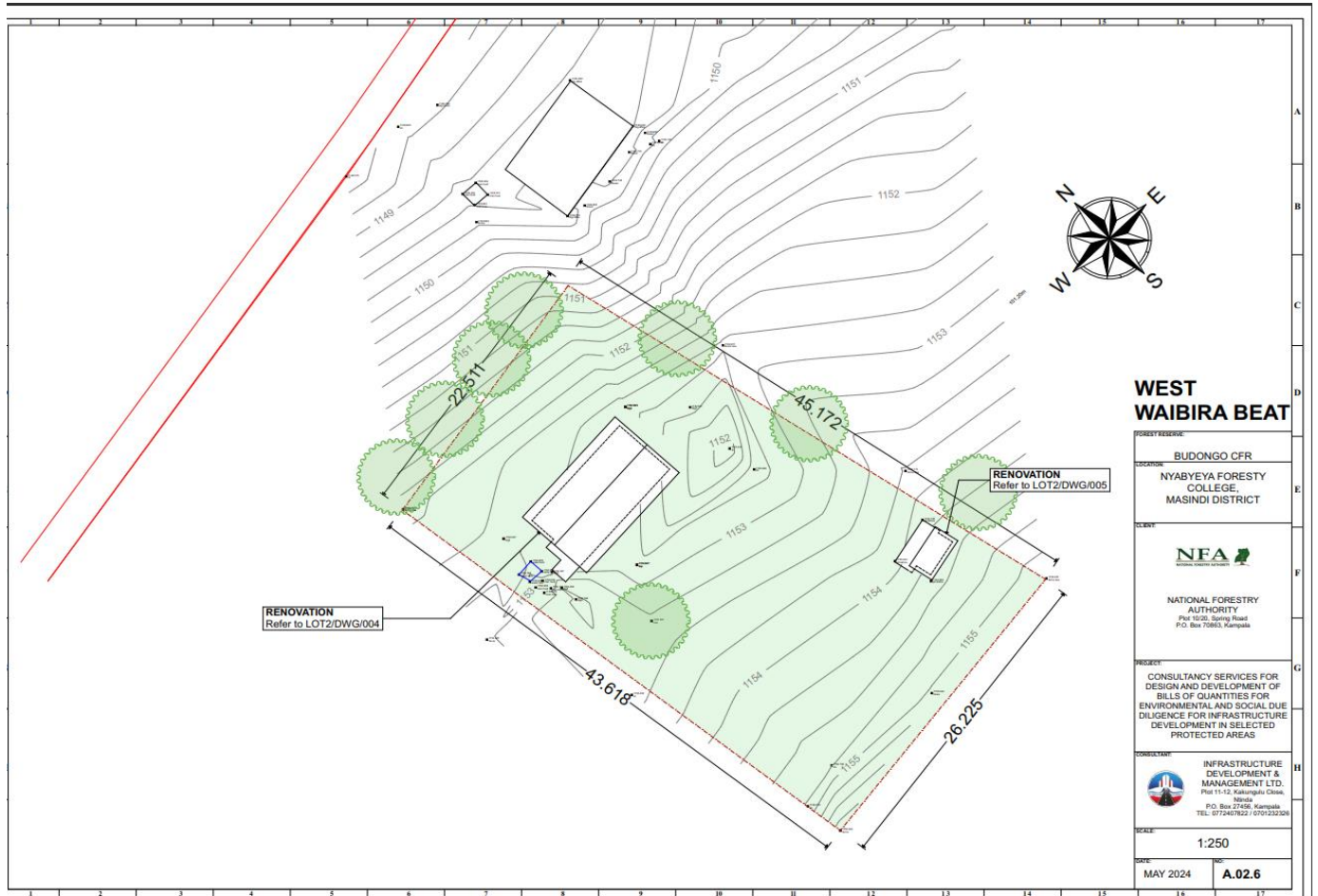
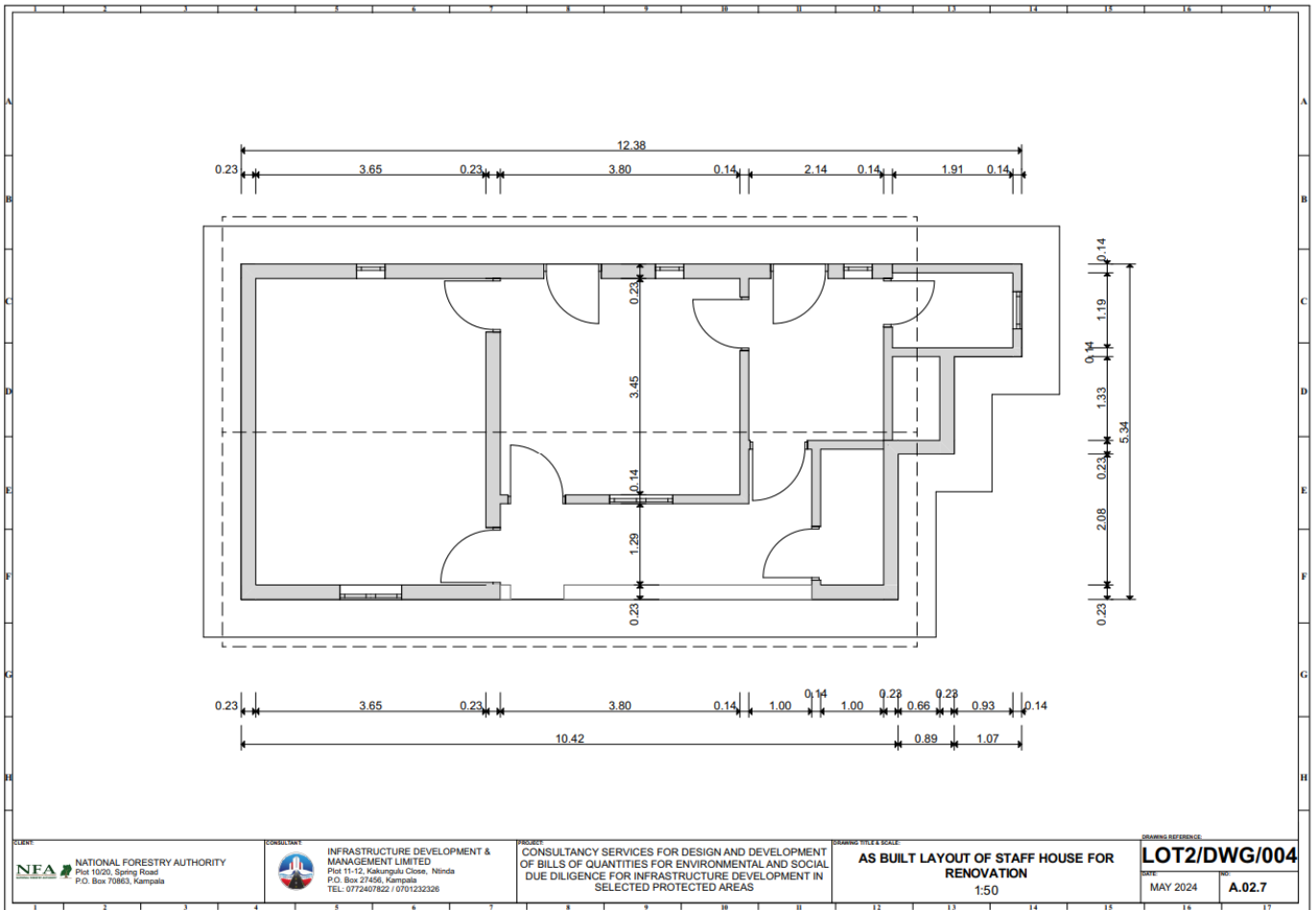

Figure 2.1: West Waibira Site Layout



<p>CLIENT NATIONAL FORESTRY AUTHORITY Plot 1020, Spring Road P.O. Box 70863, Kampala</p>	<p>CONSULTANT INFRASTRUCTURE DEVELOPMENT & MANAGEMENT LIMITED Plot 11-12, Kakirigali Close, Ninda P.O. Box 27456, Kampala TEL: 0772407822 / 0701232326</p>	<p>PROJECT CONSULTANCY SERVICES FOR DESIGN AND DEVELOPMENT OF BILLS OF QUANTITIES FOR ENVIRONMENTAL AND SOCIAL DUE DILIGENCE FOR INFRASTRUCTURE DEVELOPMENT IN SELECTED PROTECTED AREAS</p>	<p>DESIGNER TITLE & SCALE AS BUILT LAYOUT OF STAFF HOUSE FOR RENOVATION 1:50</p>	<p>DRAWING REFERENCE LOT2/DWG/004 DATE: MAY 2024 REV: A.02.7</p>
---	---	--	---	--

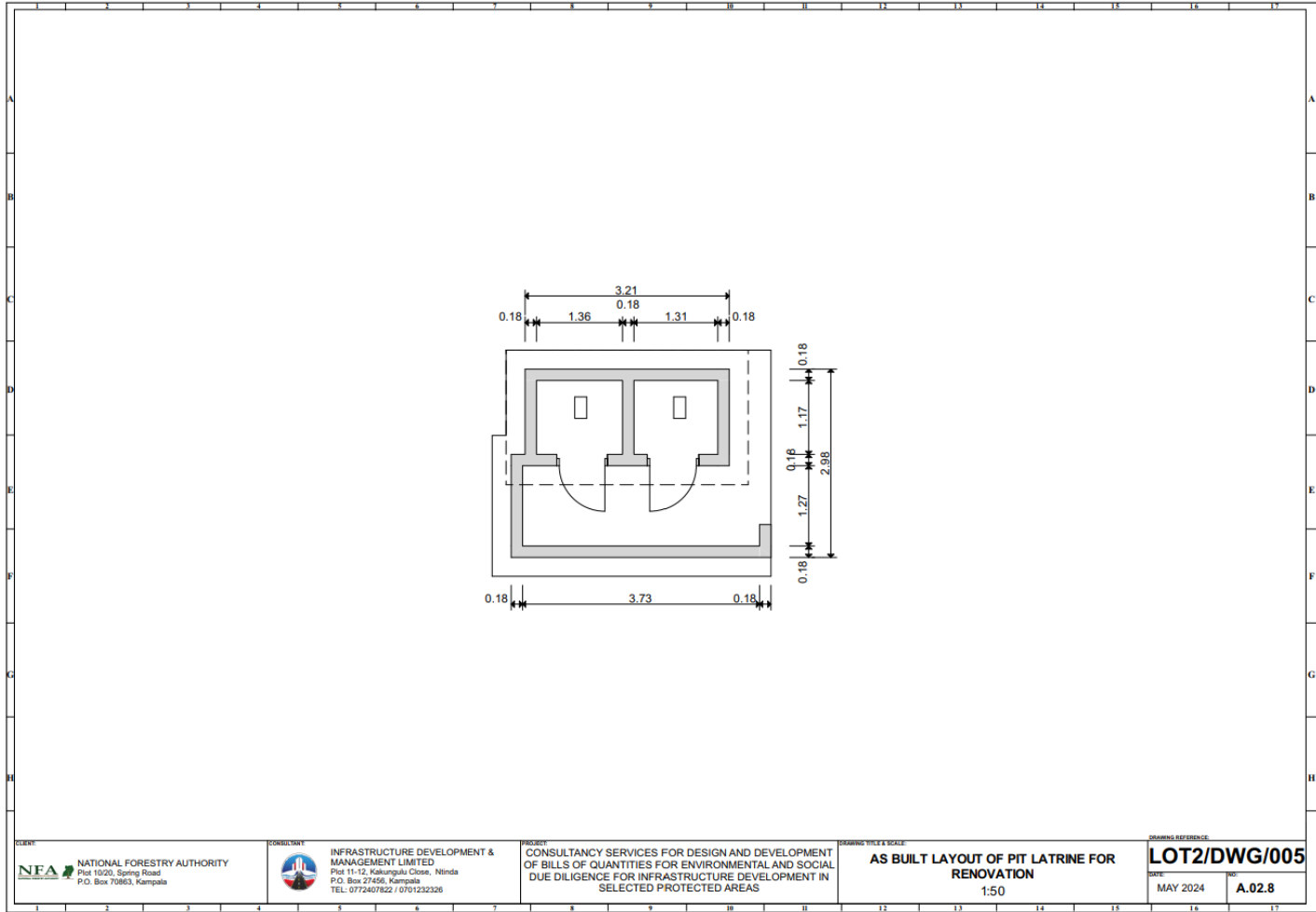

Figure 2.2: West Waibira Renovation drawings

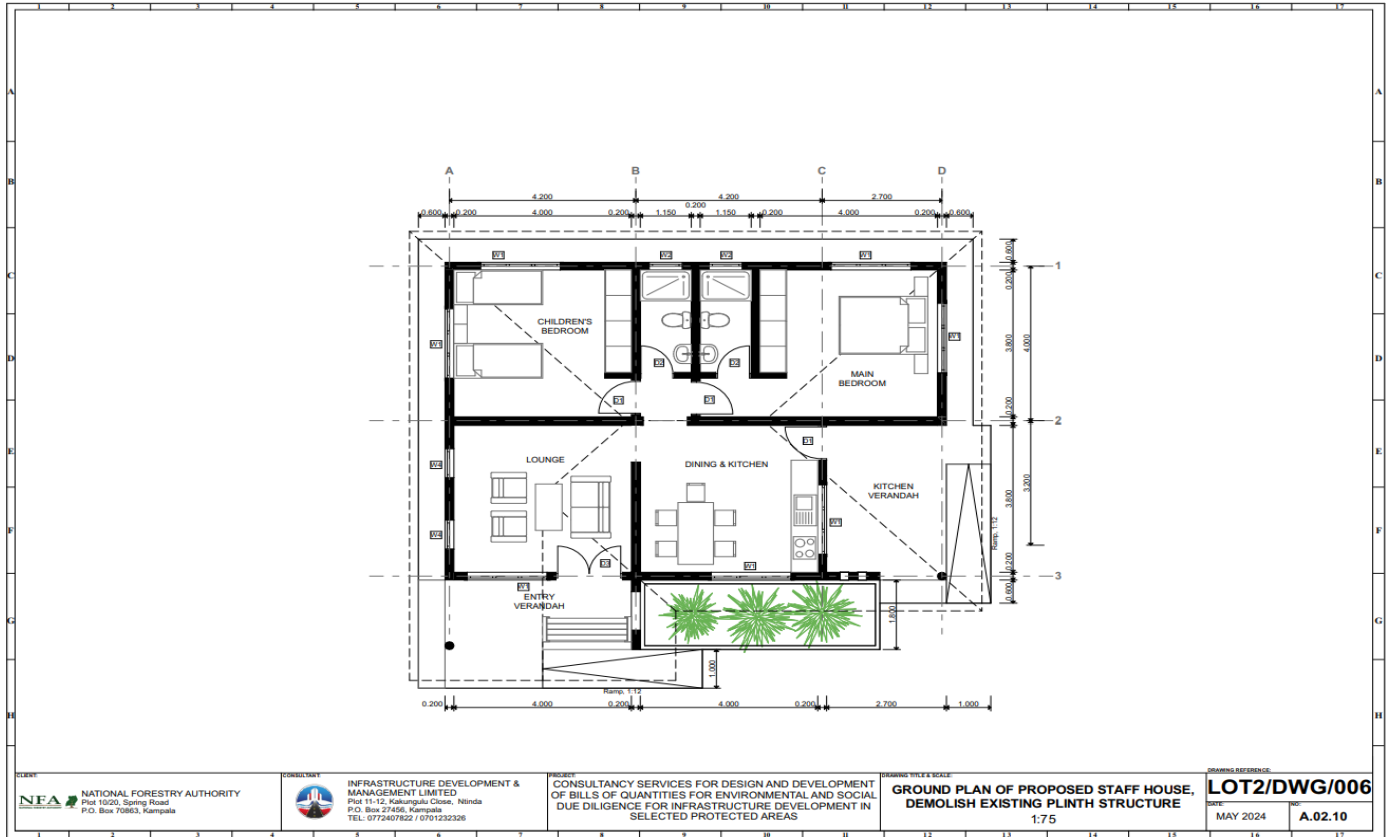

Figure 2.3: Amaply site Renovation drawings

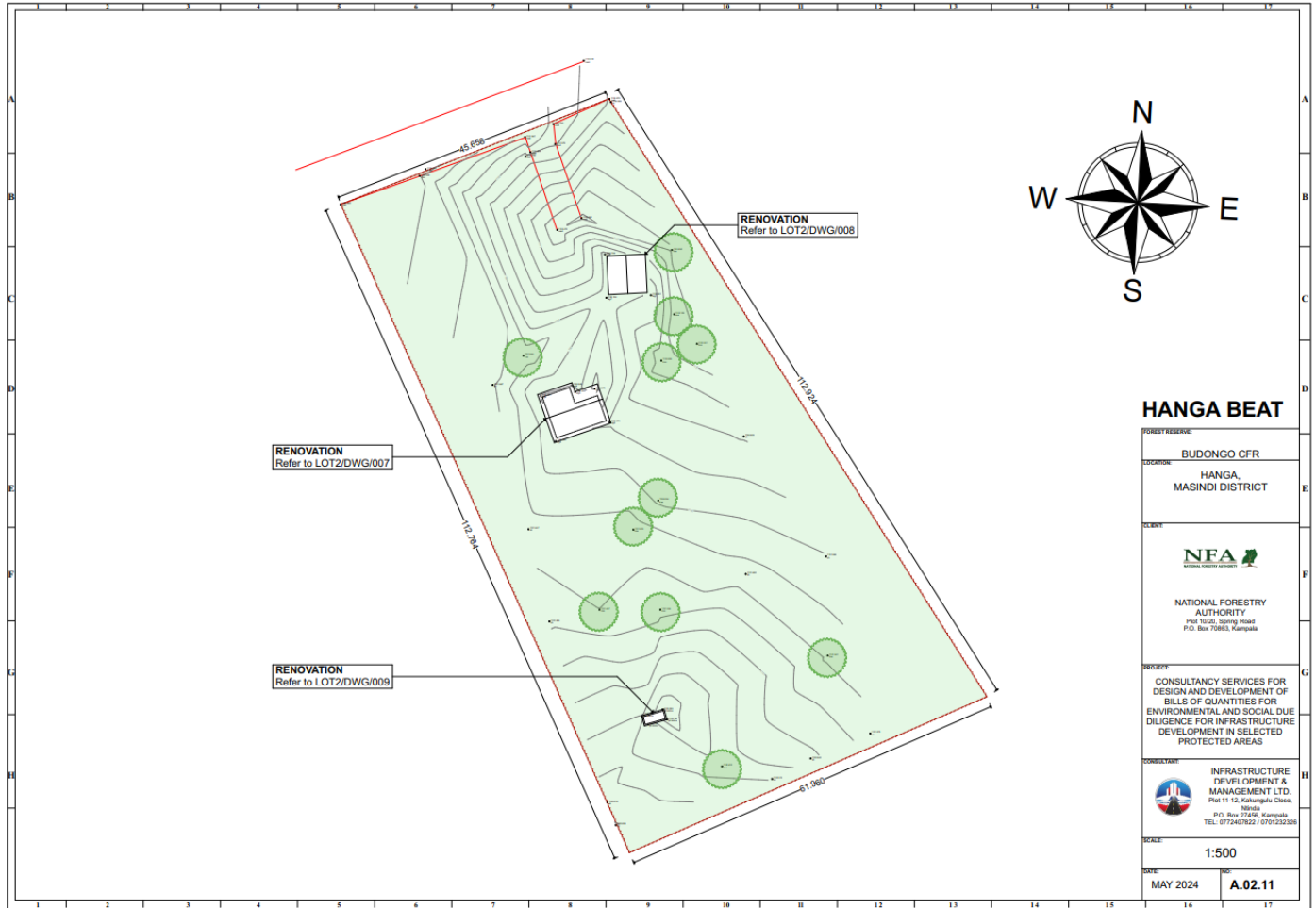
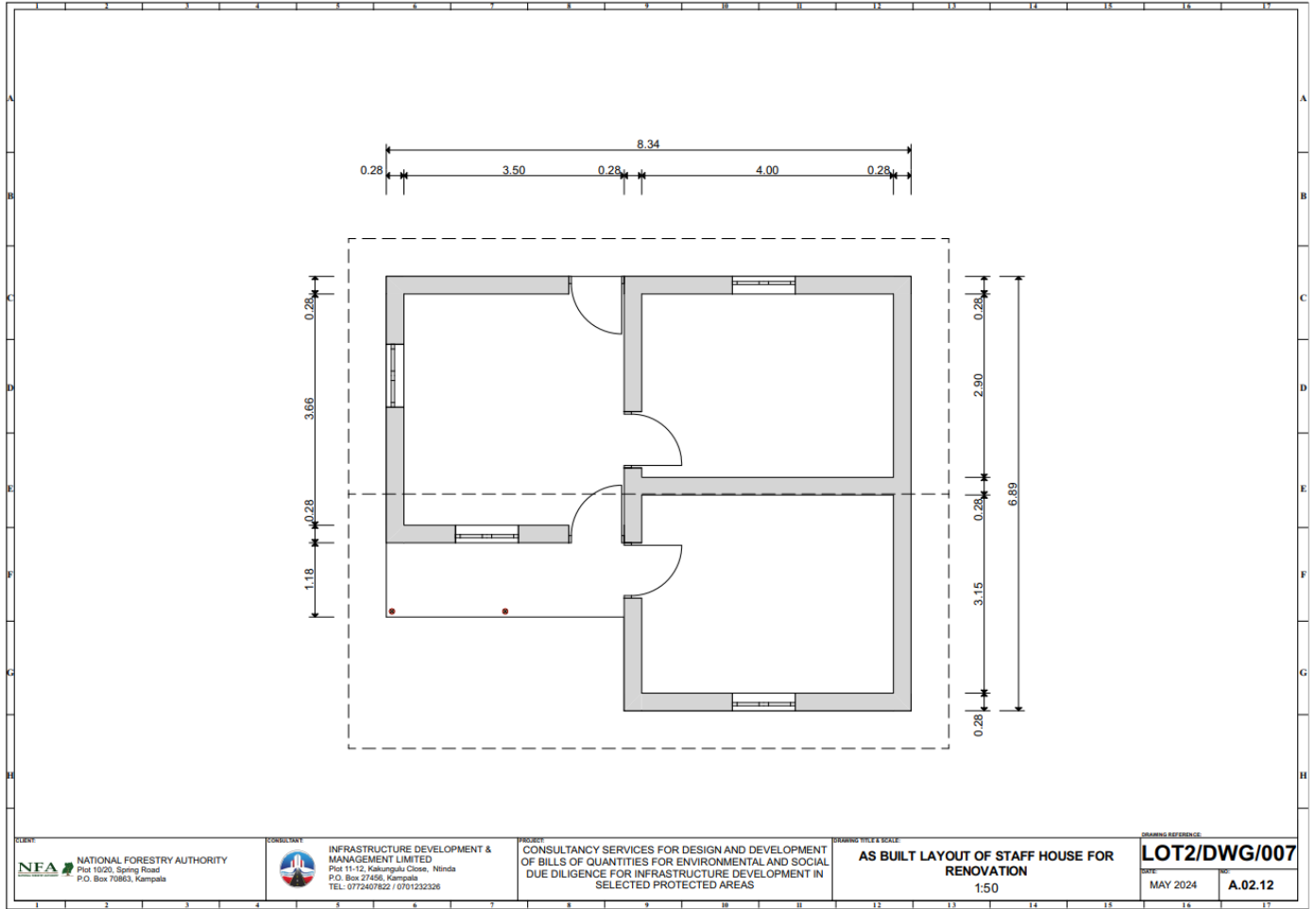

Figure 2.4: Hanga beat Site Layout



CLIENT
NATIONAL FORESTRY AUTHORITY
Plot 19/20, Spring Road
P.O. Box 70663, Kampala

CONSULTANT
INFRASTRUCTURE DEVELOPMENT & MANAGEMENT LIMITED
Plot 11-12, Kakungulu Close, Ninda
P.O. Box 27456, Kampala
TEL: 0772407622 / 0701232326

PROJECT
CONSULTANCY SERVICES FOR DESIGN AND DEVELOPMENT OF BILLS OF QUANTITIES FOR ENVIRONMENTAL AND SOCIAL DUE DILIGENCE FOR INFRASTRUCTURE DEVELOPMENT IN SELECTED PROTECTED AREAS

DRAWING TITLE & SCALE
AS BUILT LAYOUT OF STAFF HOUSE FOR RENOVATION
1:50

DRAWING REFERENCE
LOT2/DWG/007
MAY 2024
A.02.12

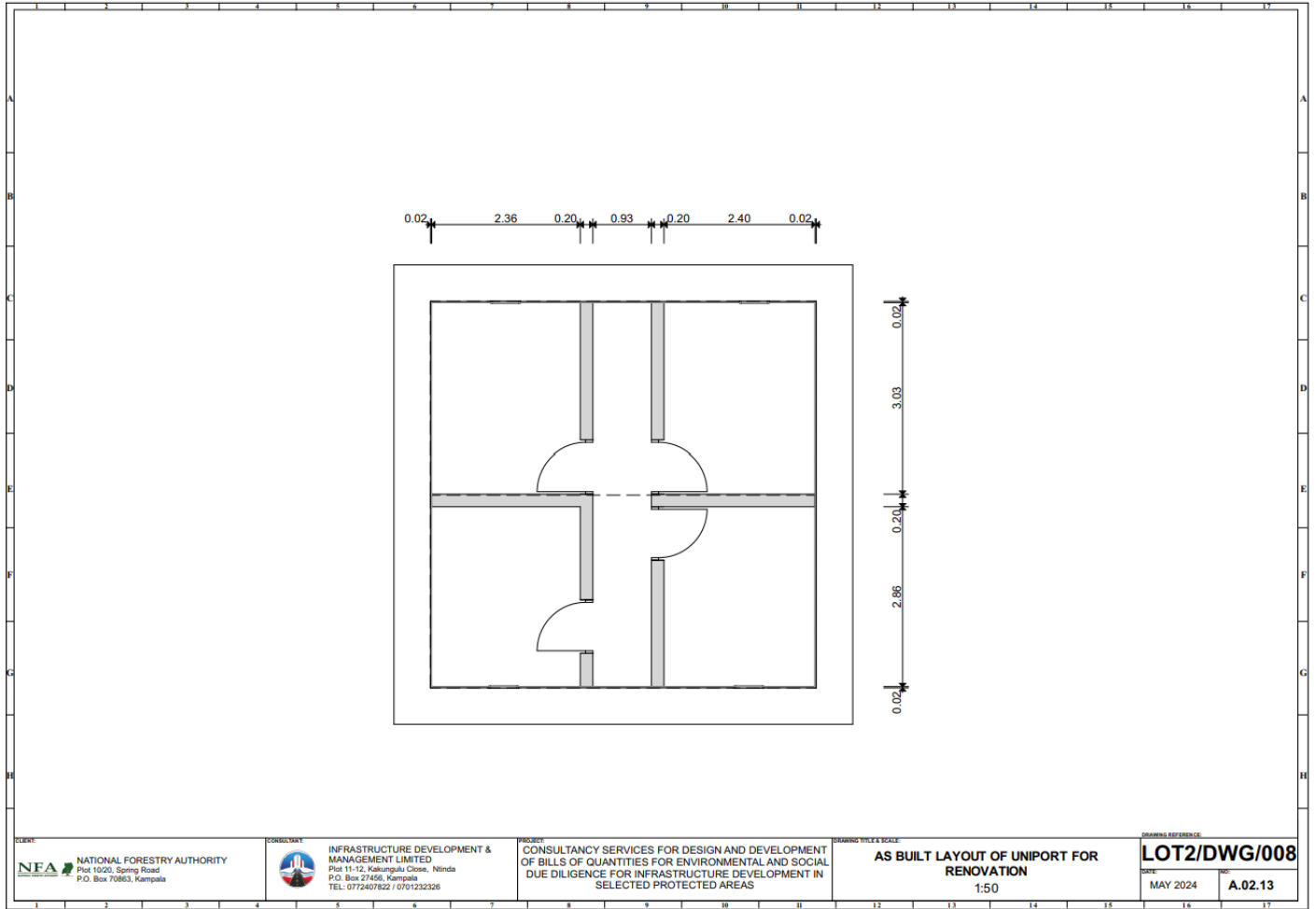

CLIENT
NATIONAL FORESTRY AUTHORITY
Plot 1020, Spring Road
P.O. Box 70863, Kampala

CONSULTANT
INFRASTRUCTURE DEVELOPMENT & MANAGEMENT LIMITED
Plot 11-12, Kakungulu Close, Ninda
P.O. Box 27456, Kampala
TEL: 0772407822 / 0701232326

PROJECT
CONSULTANCY SERVICES FOR DESIGN AND DEVELOPMENT OF BILLS OF QUANTITIES FOR ENVIRONMENTAL AND SOCIAL DUE DILIGENCE FOR INFRASTRUCTURE DEVELOPMENT IN SELECTED PROTECTED AREAS

DRAWING TITLE & SCALE
AS BUILT LAYOUT OF UNIPOINT FOR RENOVATION
1:50

DRAWING REFERENCE
LOT2/DWG/008
DATE: MAY 2024
REV: A.02.13

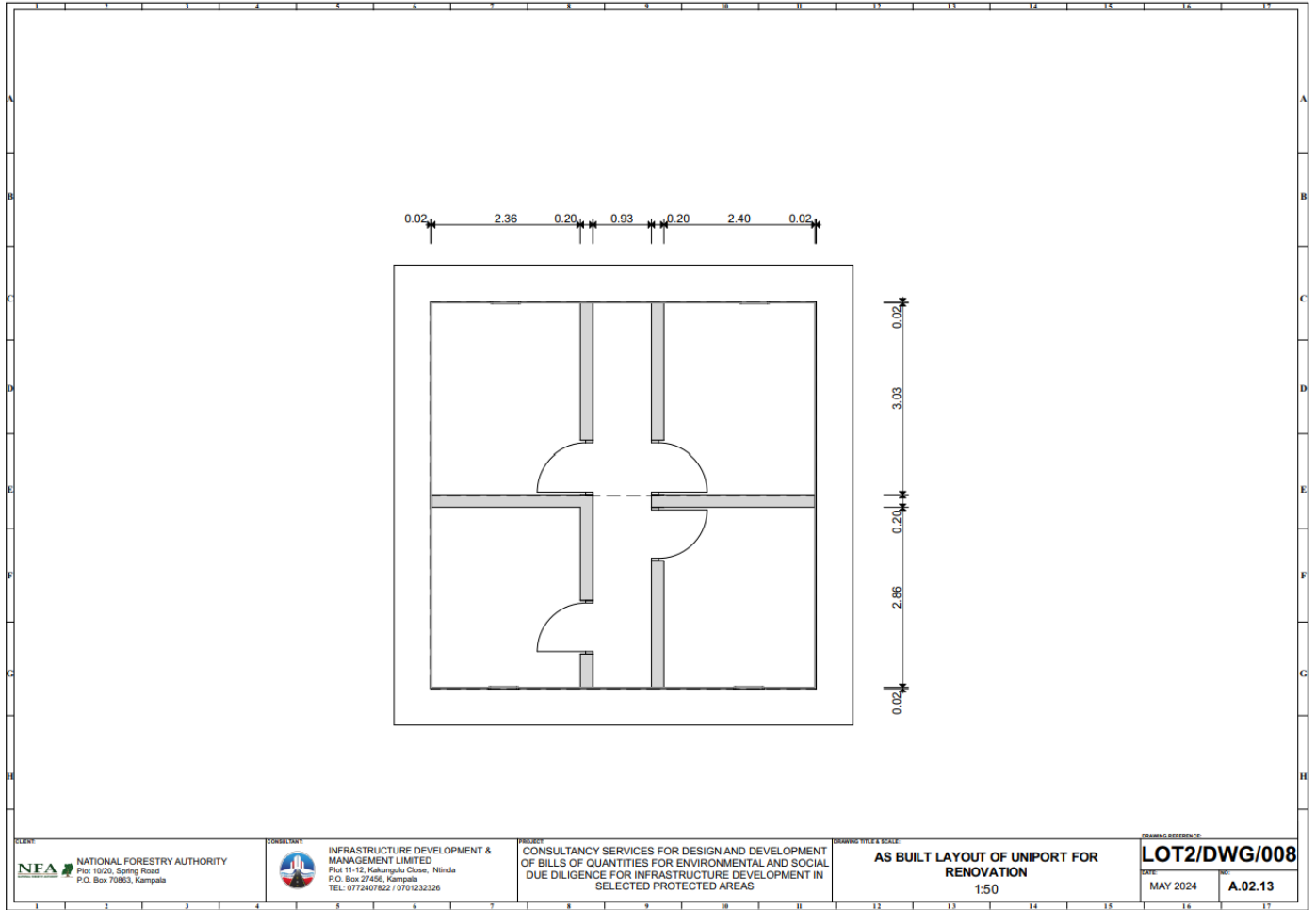

CLIENT
NATIONAL FORESTRY AUTHORITY
Plot 10/20, Spring Road
P.O. Box 70863, Kampala

CONSULTANT
INFRASTRUCTURE DEVELOPMENT & MANAGEMENT LIMITED
Plot 11-12, Kakungulu Close, Ntinda
P.O. Box 27456, Kampala
TEL: 0772407622 / 071232326

PROJECT
CONSULTANCY SERVICES FOR DESIGN AND DEVELOPMENT OF BILLS OF QUANTITIES FOR ENVIRONMENTAL AND SOCIAL DUE DILIGENCE FOR INFRASTRUCTURE DEVELOPMENT IN SELECTED PROTECTED AREAS

DRAWING TITLE & SCALE
AS BUILT LAYOUT OF UNIPORT FOR RENOVATION
1:50

DRAWING REFERENCE
LOT2/DWG/008
DATE: MAY 2024
NO: **A.02.13**

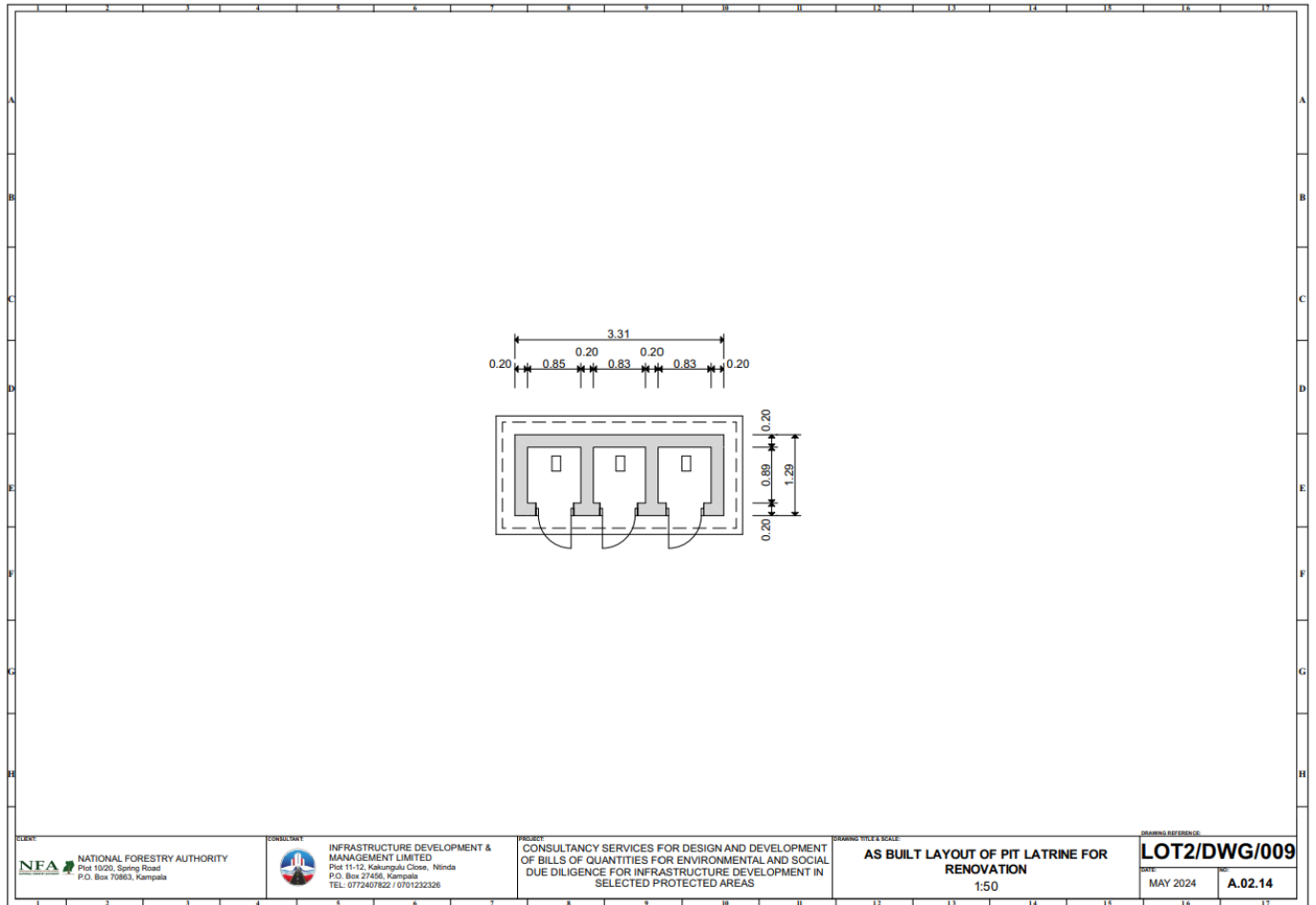
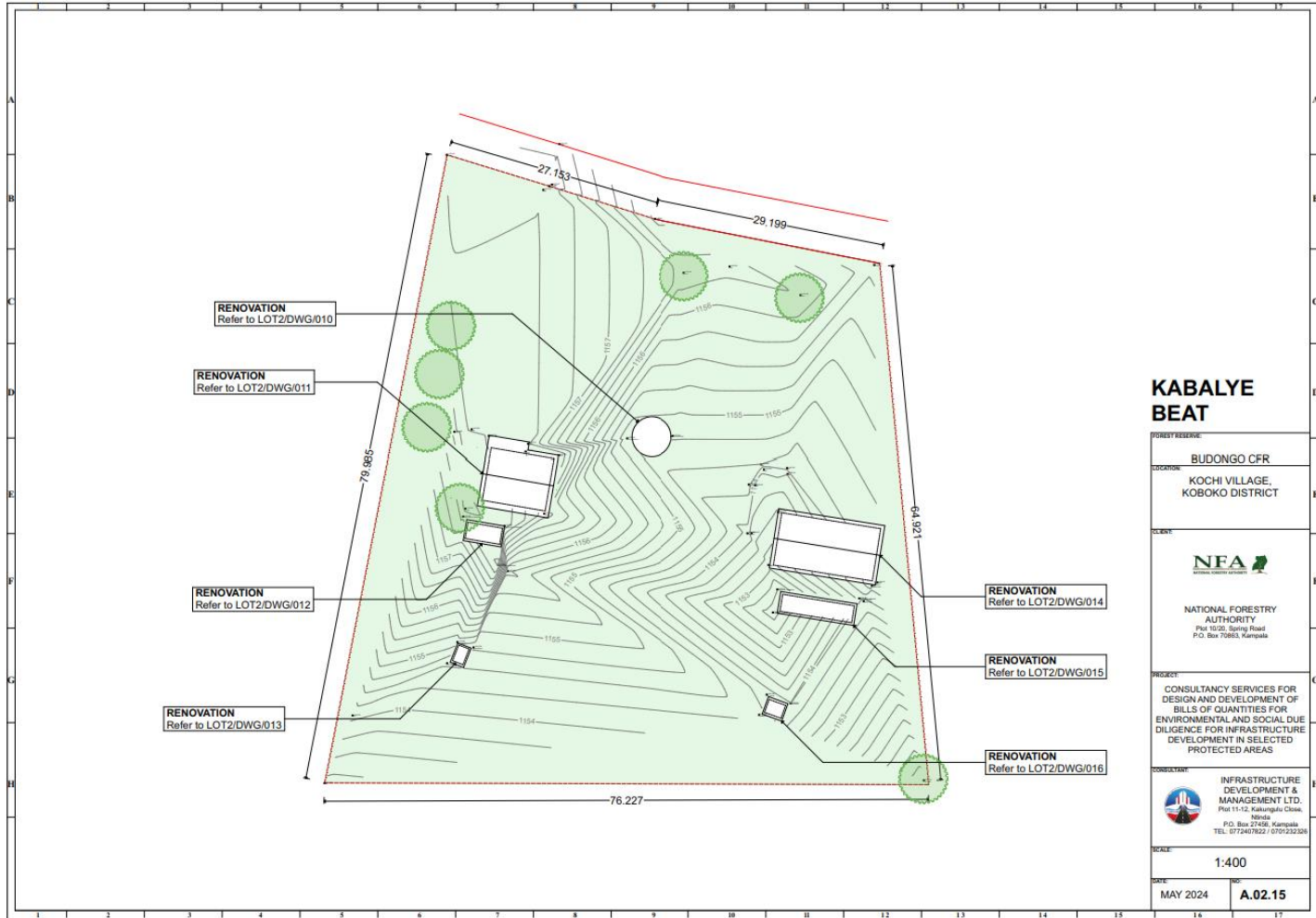

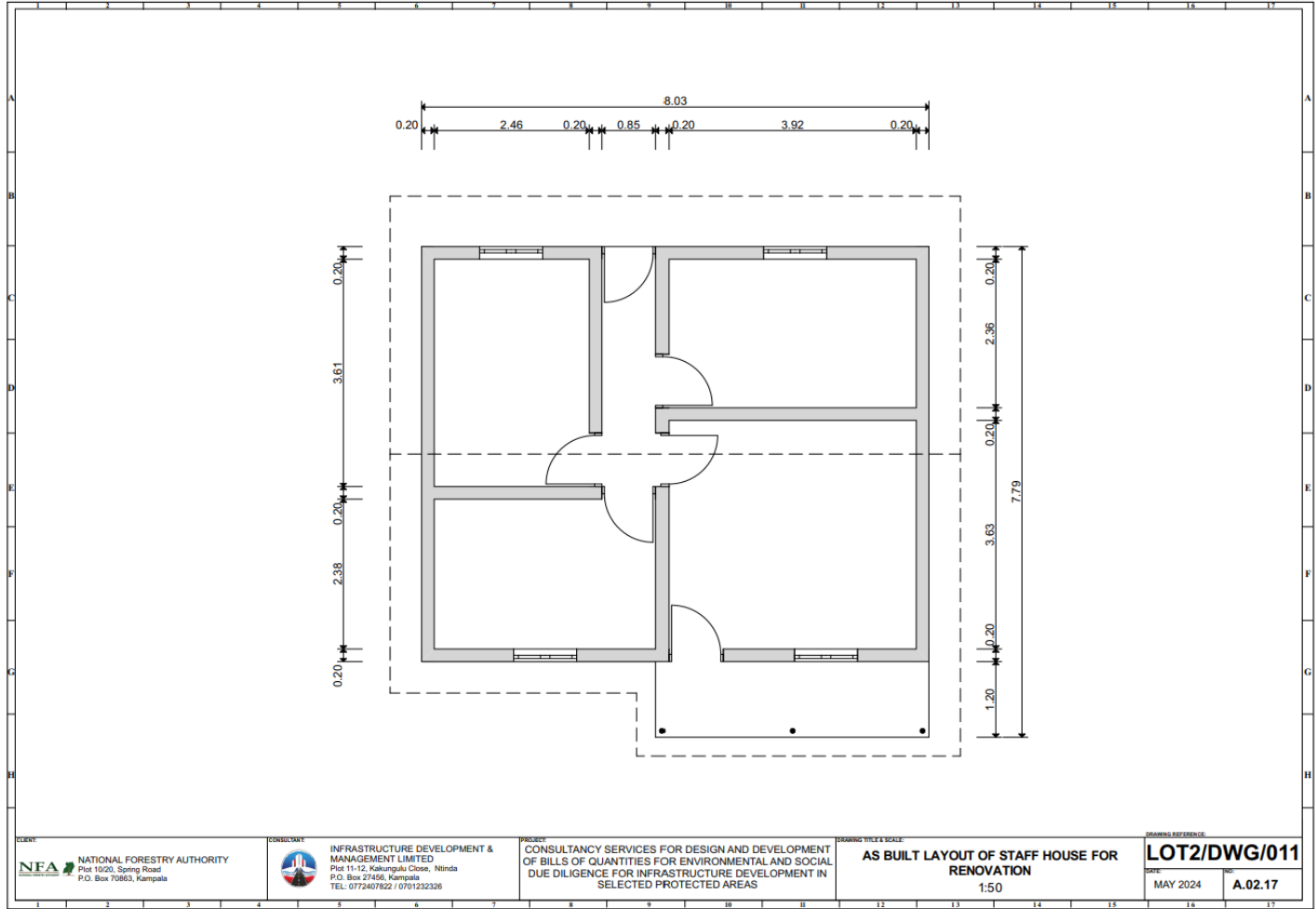

Figure 2.5: Hanga site Renovation drawings



KABALYE BEAT

FOREST RESERVE:	BUDONGO CFR
LOCATION:	KOCHI VILLAGE, KOBOKO DISTRICT
CLIENT:	 NATIONAL FORESTRY AUTHORITY Plot 1028, Spring Road P.O. Box 70883, Kampala
PROJECT:	CONSULTANCY SERVICES FOR DESIGN AND DEVELOPMENT OF BILLS OF QUANTITIES FOR ENVIRONMENTAL AND SOCIAL DUE DILIGENCE FOR INFRASTRUCTURE DEVELOPMENT IN SELECTED PROTECTED AREAS
CONSULTANT:	 INFRASTRUCTURE DEVELOPMENT & MANAGEMENT LTD. Plot 11-12, Kakungulu Close, Mbande P.O. Box 27456, Kampala TEL: 0774937622, 0702222509
SCALE:	1:400
DATE:	MAY 2024
	A.02.15



CLIENT:
NFA NATIONAL FORESTRY AUTHORITY
Plot 1020, Spring Road
P.O. Box 70863, Kampala

CONSULTANT:
INFRASTRUCTURE DEVELOPMENT & MANAGEMENT LIMITED
Plot 11-12, Kakungulu Close, Ninda
P.O. Box 27456, Kampala
TEL: 0772407822 / 0701232326

PROJECT:
CONSULTANCY SERVICES FOR DESIGN AND DEVELOPMENT OF BILLS OF QUANTITIES FOR ENVIRONMENTAL AND SOCIAL DUE DILIGENCE FOR INFRASTRUCTURE DEVELOPMENT IN SELECTED PROTECTED AREAS

DRAWING TITLE & SCALE:
AS BUILT LAYOUT OF STAFF HOUSE FOR RENOVATION
1:50

DRAWING REFERENCE:
LOT2/DWG/011
DATE: MAY 2024
NO: **A.02.17**

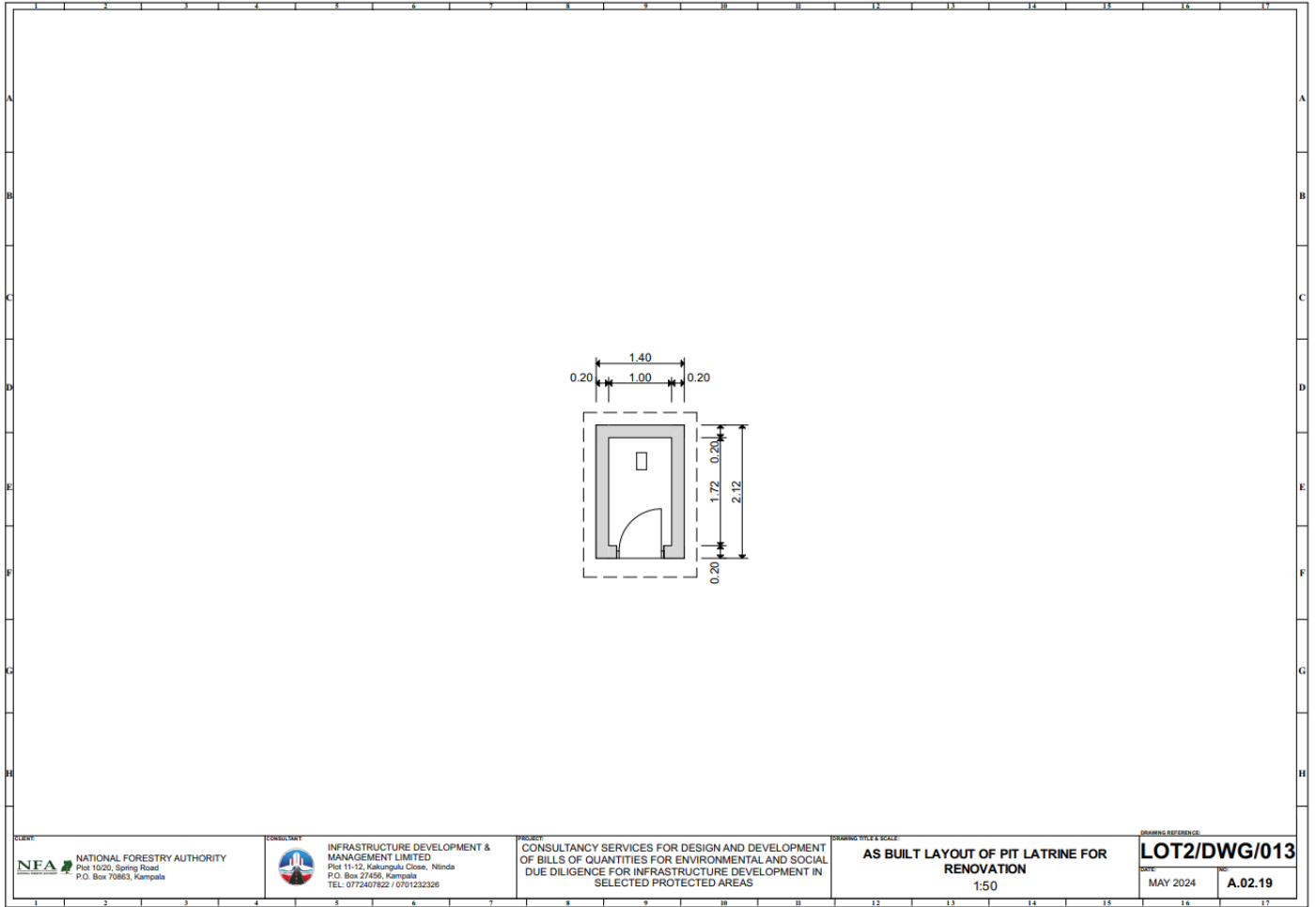

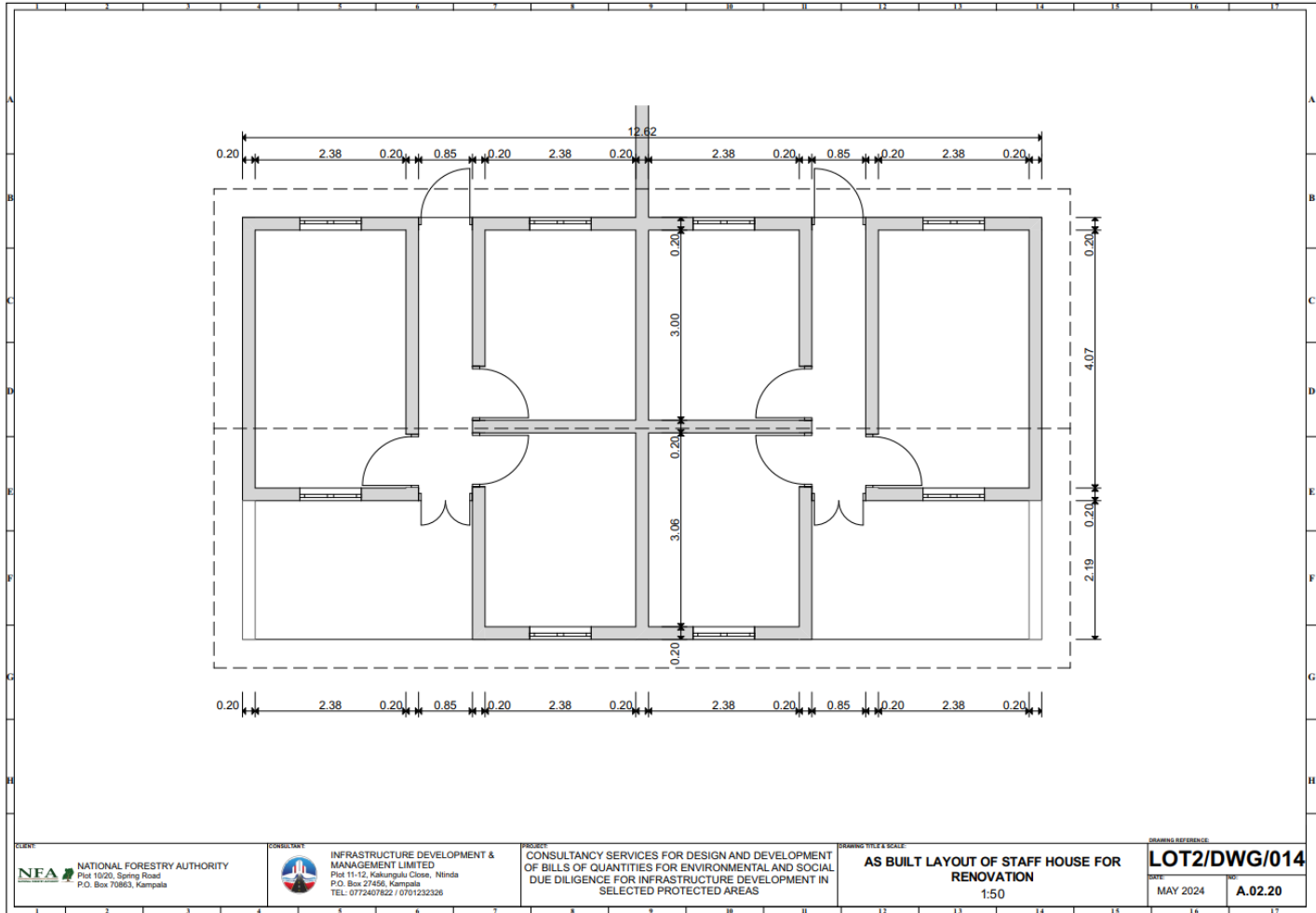

CLIENT
NATIONAL FORESTRY AUTHORITY
Plot 1020, Spring Road
P.O. Box 70863, Kampala

CONSULTANT
INFRASTRUCTURE DEVELOPMENT & MANAGEMENT LIMITED
Plot 11-12, Kakungulu Close, Ninda
P.O. Box 27456, Kampala
TEL: 0772407822 / 0791232326

PROJECT
CONSULTANCY SERVICES FOR DESIGN AND DEVELOPMENT OF BILLS OF QUANTITIES FOR ENVIRONMENTAL AND SOCIAL DUE DILIGENCE FOR INFRASTRUCTURE DEVELOPMENT IN SELECTED PROTECTED AREAS

DRAWING TITLE & SCALE
AS BUILT LAYOUT OF STAFF HOUSE FOR RENOVATION
1:50

DRAWING REFERENCE
LOT2/DWG/014
DATE: MAY 2024
NO: A.02.20

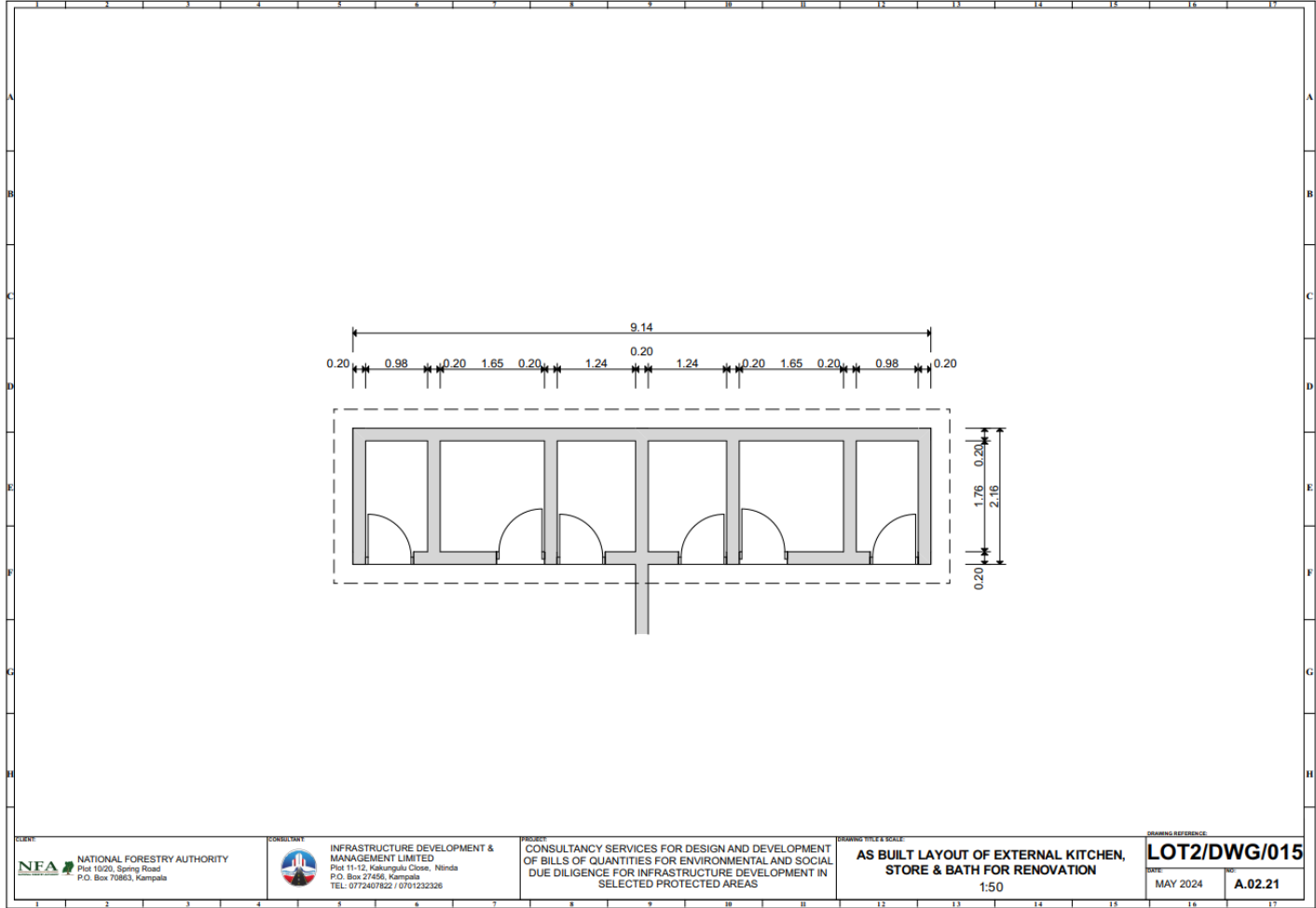

CLIENT
NATIONAL FORESTRY AUTHORITY
Plot 1020, Spring Road
P.O. Box 70863, Kampala

CONSULTANT
INFRASTRUCTURE DEVELOPMENT & MANAGEMENT LIMITED
Plot 11-12, Kakungulu Close, Ntinda
P.O. Box 27456, Kampala
TEL: 0772407822 / 0701232326

PROJECT
CONSULTANCY SERVICES FOR DESIGN AND DEVELOPMENT OF BILLS OF QUANTITIES FOR ENVIRONMENTAL AND SOCIAL DUE DILIGENCE FOR INFRASTRUCTURE DEVELOPMENT IN SELECTED PROTECTED AREAS

DRAWING TITLE & SCALE
AS BUILT LAYOUT OF EXTERNAL KITCHEN, STORE & BATH FOR RENOVATION
1:50

DRAWING REFERENCE
LOT2/DWG/015
DATE: MAY 2024
NO: A.02.21

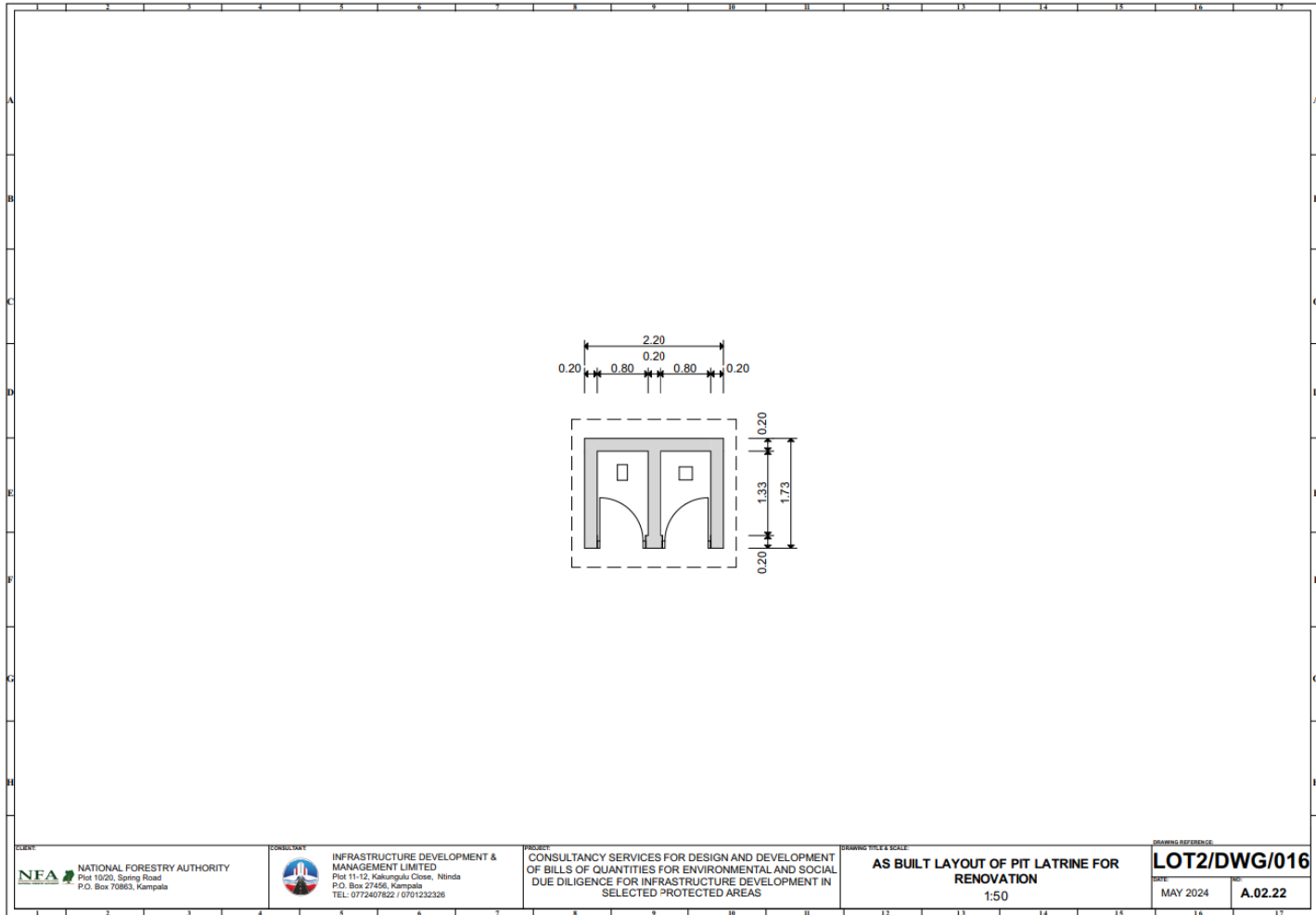
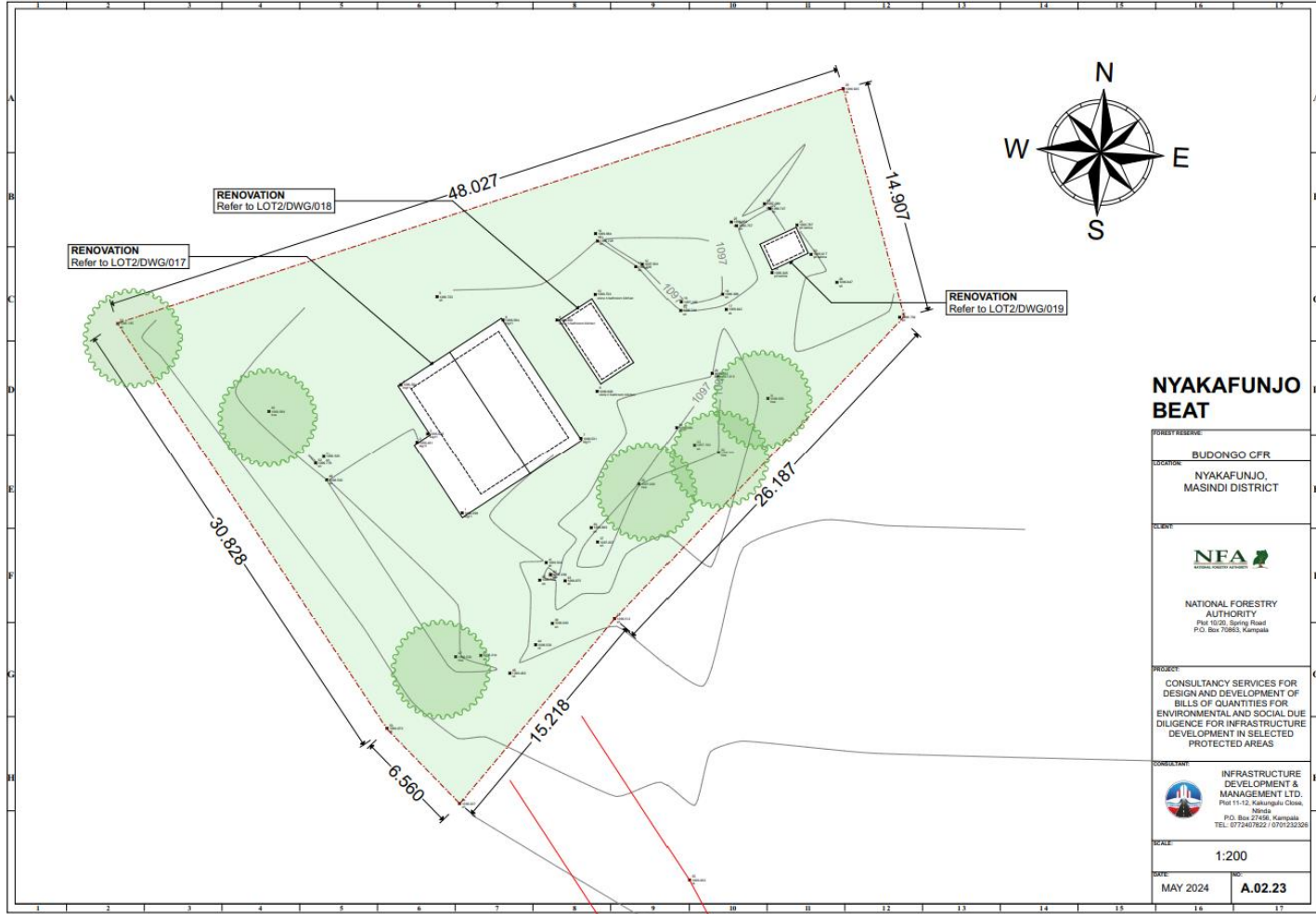
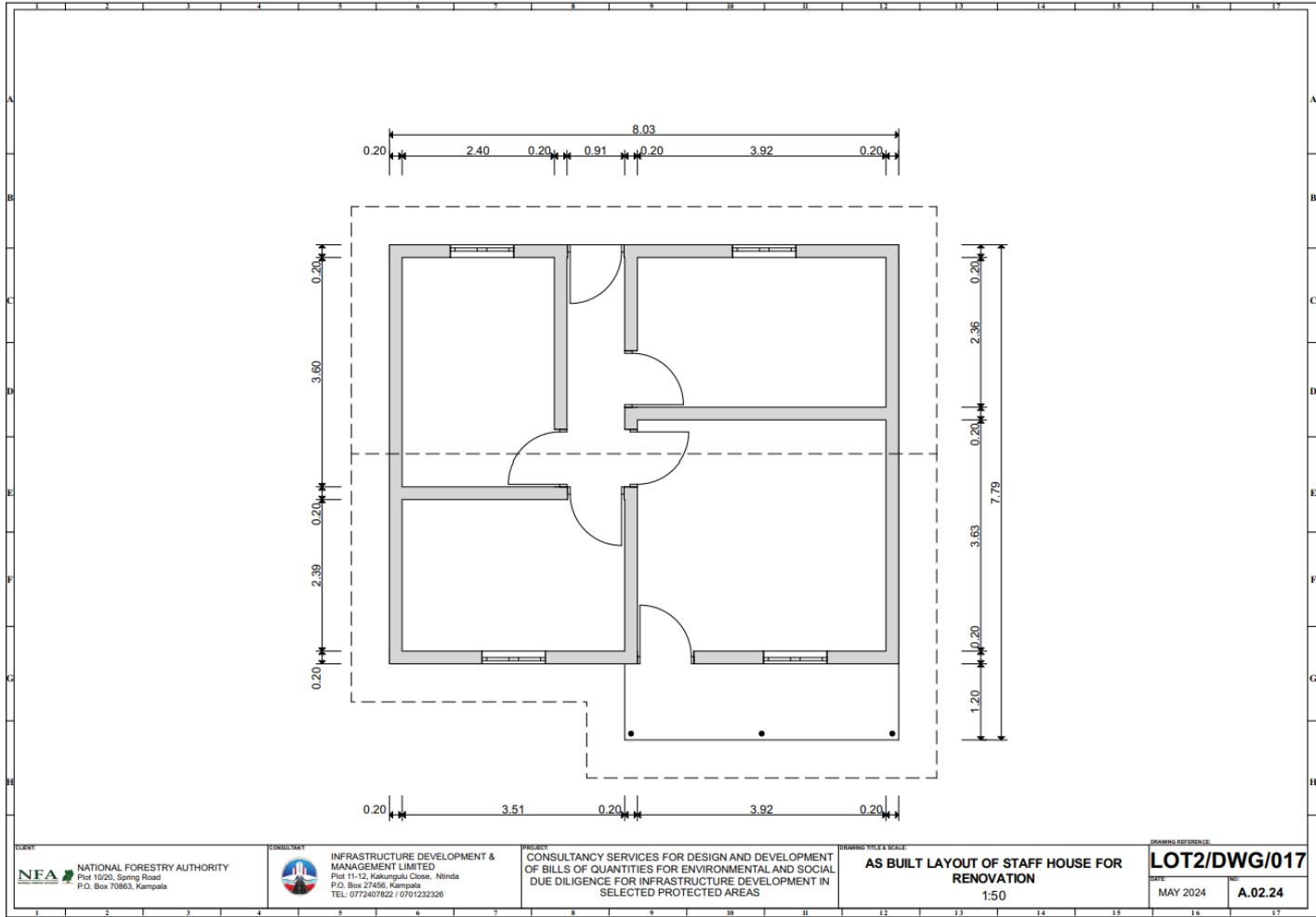

Figure 2.6: Kabalye site Renovation drawings





CLIENT
NATIONAL FORESTRY AUTHORITY
Plot 10/20, Spring Road
P.O. Box 70963, Kampala

CONSULTANT
INFRASTRUCTURE DEVELOPMENT & MANAGEMENT LIMITED
Plot 11-12, Kakungulu Close, Ninda
P.O. Box 27456, Kampala
TEL: 0772407822 / 0701232326

PROJECT
CONSULTANCY SERVICES FOR DESIGN AND DEVELOPMENT OF BILLS OF QUANTITIES FOR ENVIRONMENTAL AND SOCIAL DUE DILIGENCE FOR INFRASTRUCTURE DEVELOPMENT IN SELECTED PROTECTED AREAS

DRAWING TITLE & SCALE
AS BUILT LAYOUT OF STAFF HOUSE FOR RENOVATION
1:50

DRAWING REFERENCE
LOT2/DWG/017
DATE: MAY 2024
DC: A.02.24

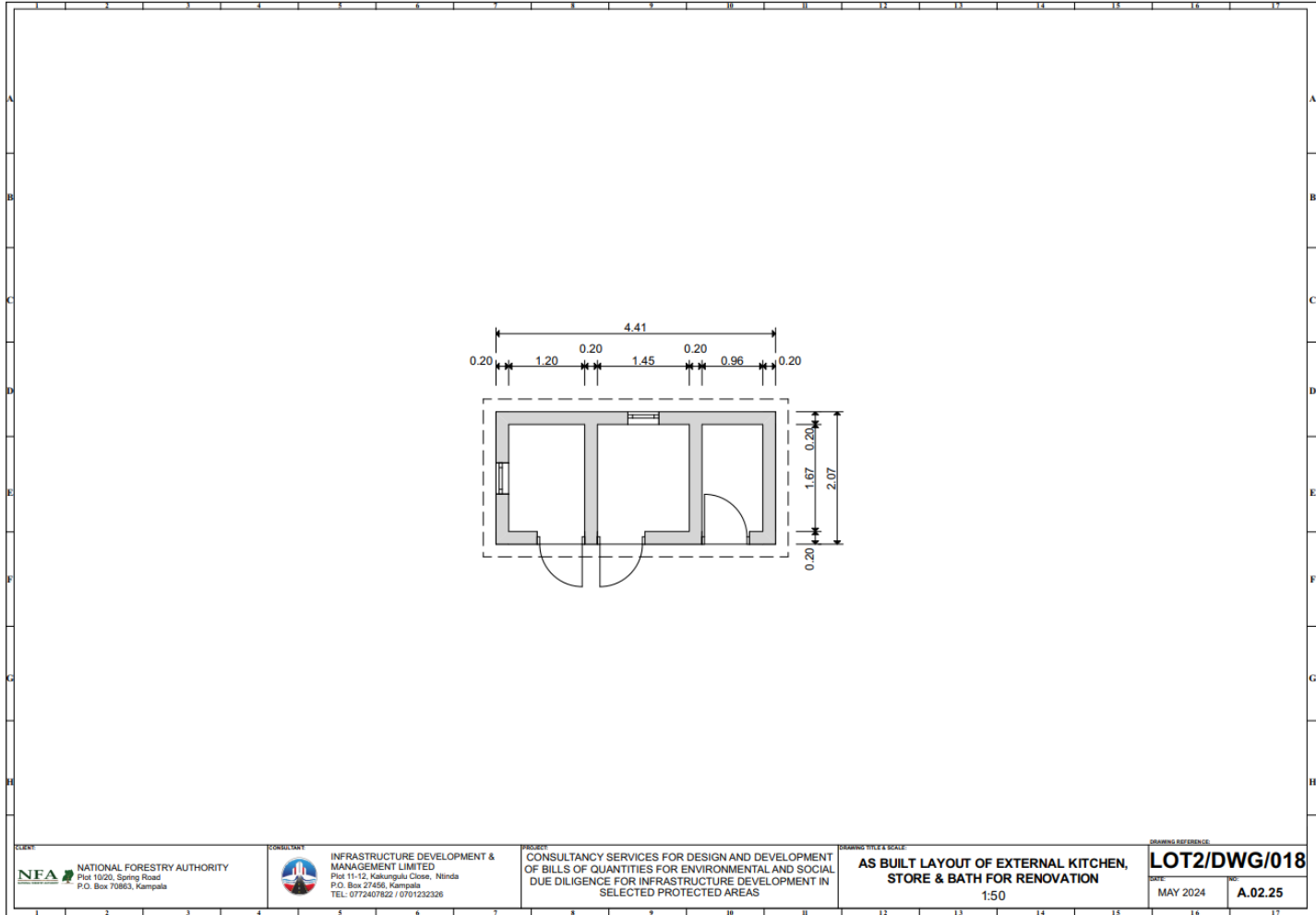

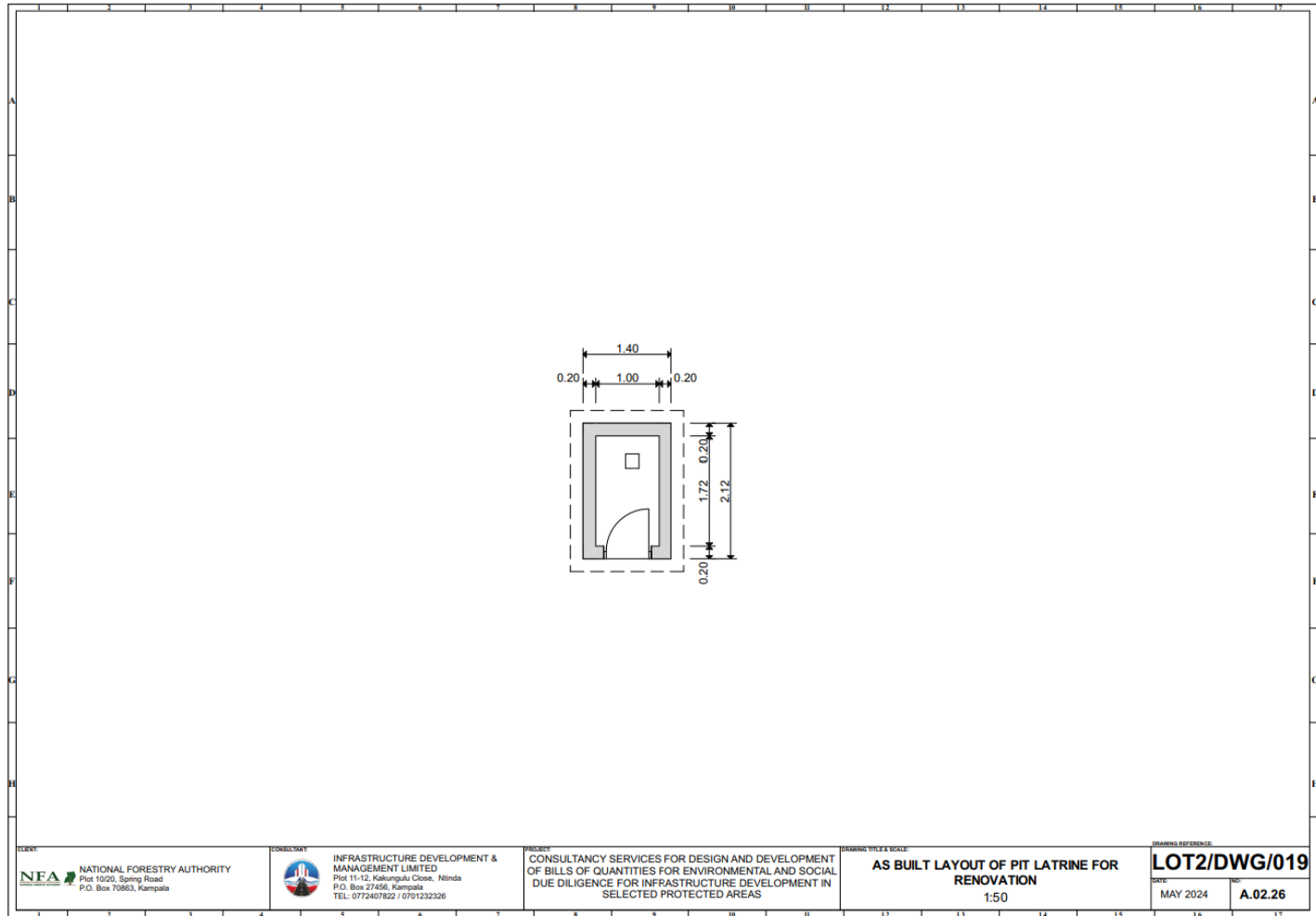
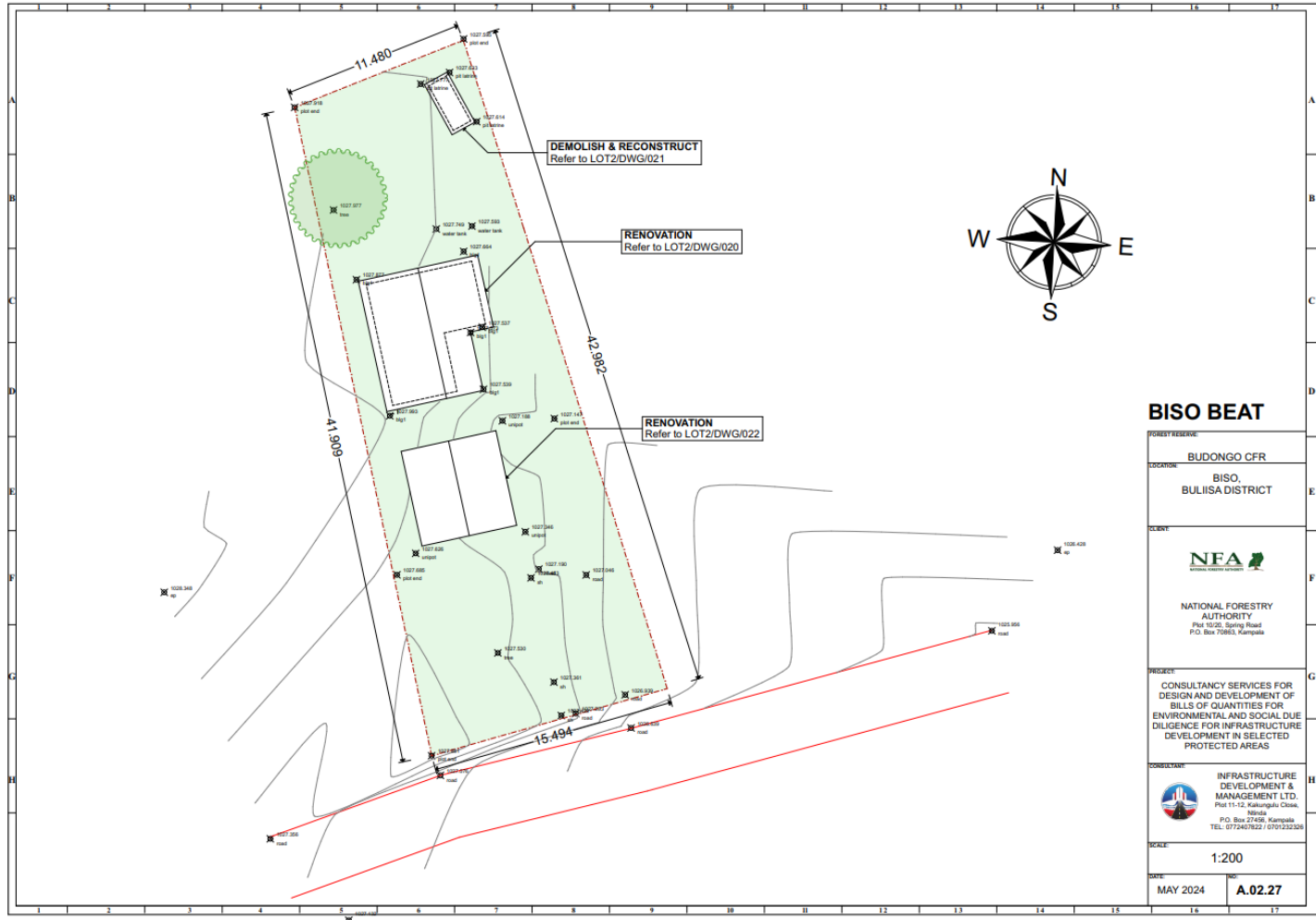

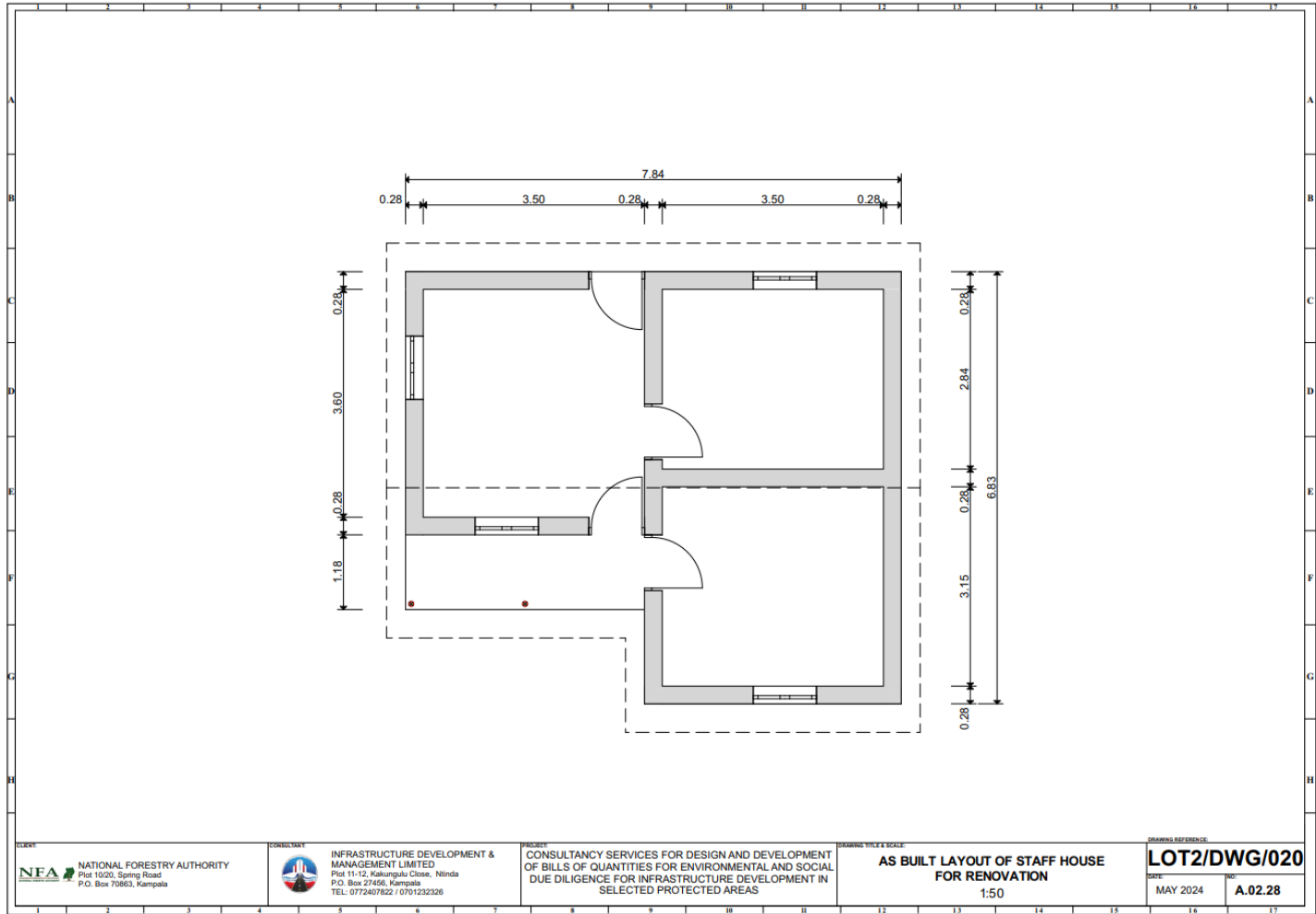

Figure 2.7: Nyakafunjo site Renovation drawings



BISO BEAT

FORREST RESERVE:	BUDONGO CFR
LOCATION:	BISO, BULIISA DISTRICT
CLIENT:	 NATIONAL FORESTRY AUTHORITY Plot 10/25, Spring Road P.O. Box 70885, Kampala
PROJECT:	CONSULTANCY SERVICES FOR DESIGN AND DEVELOPMENT OF BILLS OF QUANTITIES FOR ENVIRONMENTAL AND SOCIAL DUE DILIGENCE FOR INFRASTRUCTURE DEVELOPMENT IN SELECTED PROTECTED AREAS
CONSULTANT:	 INFRASTRUCTURE DEVELOPMENT & MANAGEMENT LTD. Plot 11/12, Katurukya, Oloka 29/04 P.O. Box 27456, Kampala TEL: 0772407822 / 0702323208
SCALE:	1:200
DATE:	MAY 2024
NO.:	A.02.27



CLIENT:
NATIONAL FORESTRY AUTHORITY
Plot 1020, Spring Road
P.O. Box 70863, Kampala

CONSULTANT:
INFRASTRUCTURE DEVELOPMENT & MANAGEMENT LIMITED
Plot 11-12, Kakungulu Close, Ntinda
P.O. Box 27456, Kampala
TEL: 0772407822 / 0701232326

PROJECT:
CONSULTANCY SERVICES FOR DESIGN AND DEVELOPMENT OF BILLS OF QUANTITIES FOR ENVIRONMENTAL AND SOCIAL DUE DILIGENCE FOR INFRASTRUCTURE DEVELOPMENT IN SELECTED PROTECTED AREAS

DRAWING TITLE & SCALE:
AS BUILT LAYOUT OF STAFF HOUSE FOR RENOVATION
1:50

DRAWING REFERENCE:
LOT2/DWG/020
DATE: MAY 2024
NO: **A.02.28**

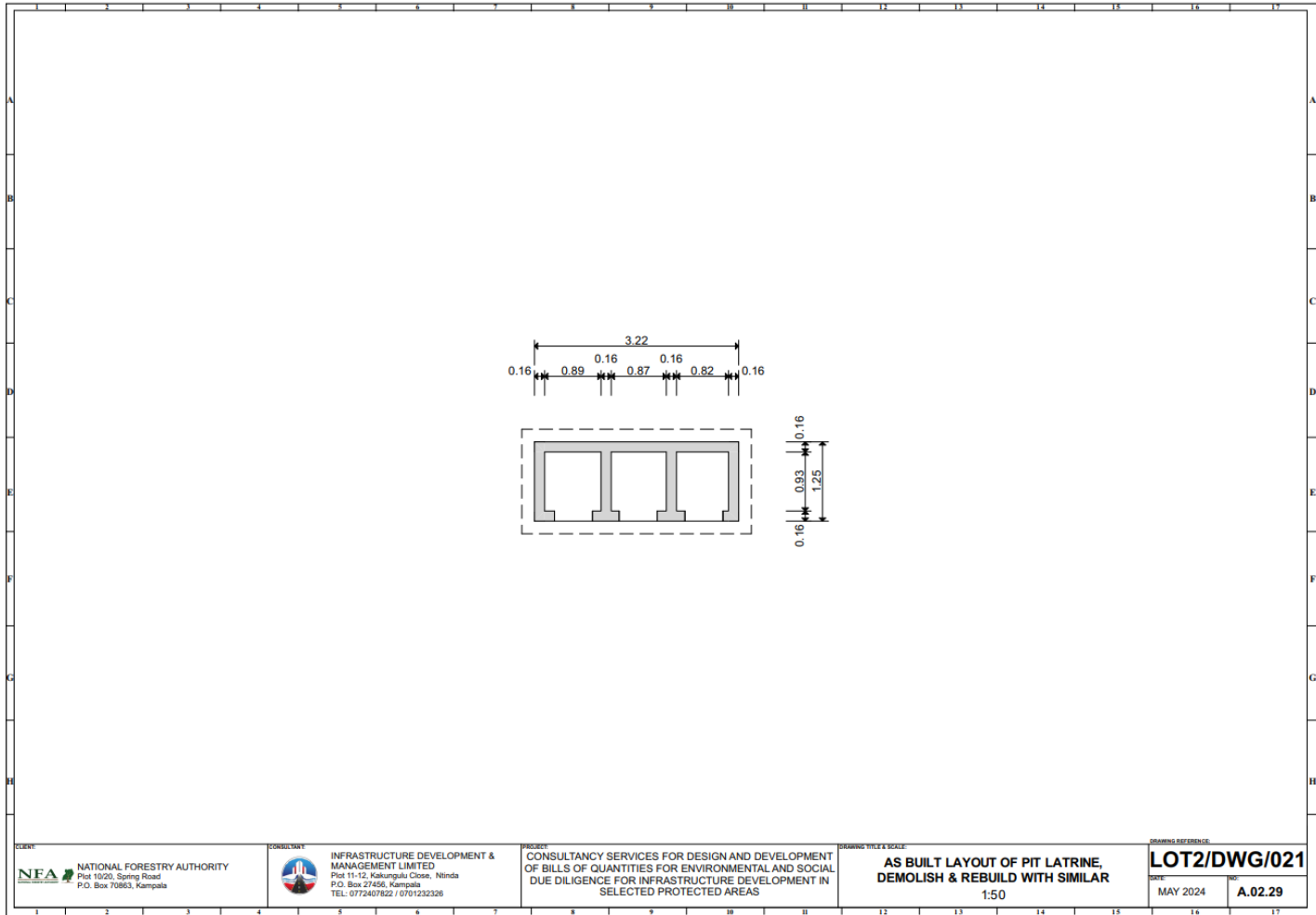

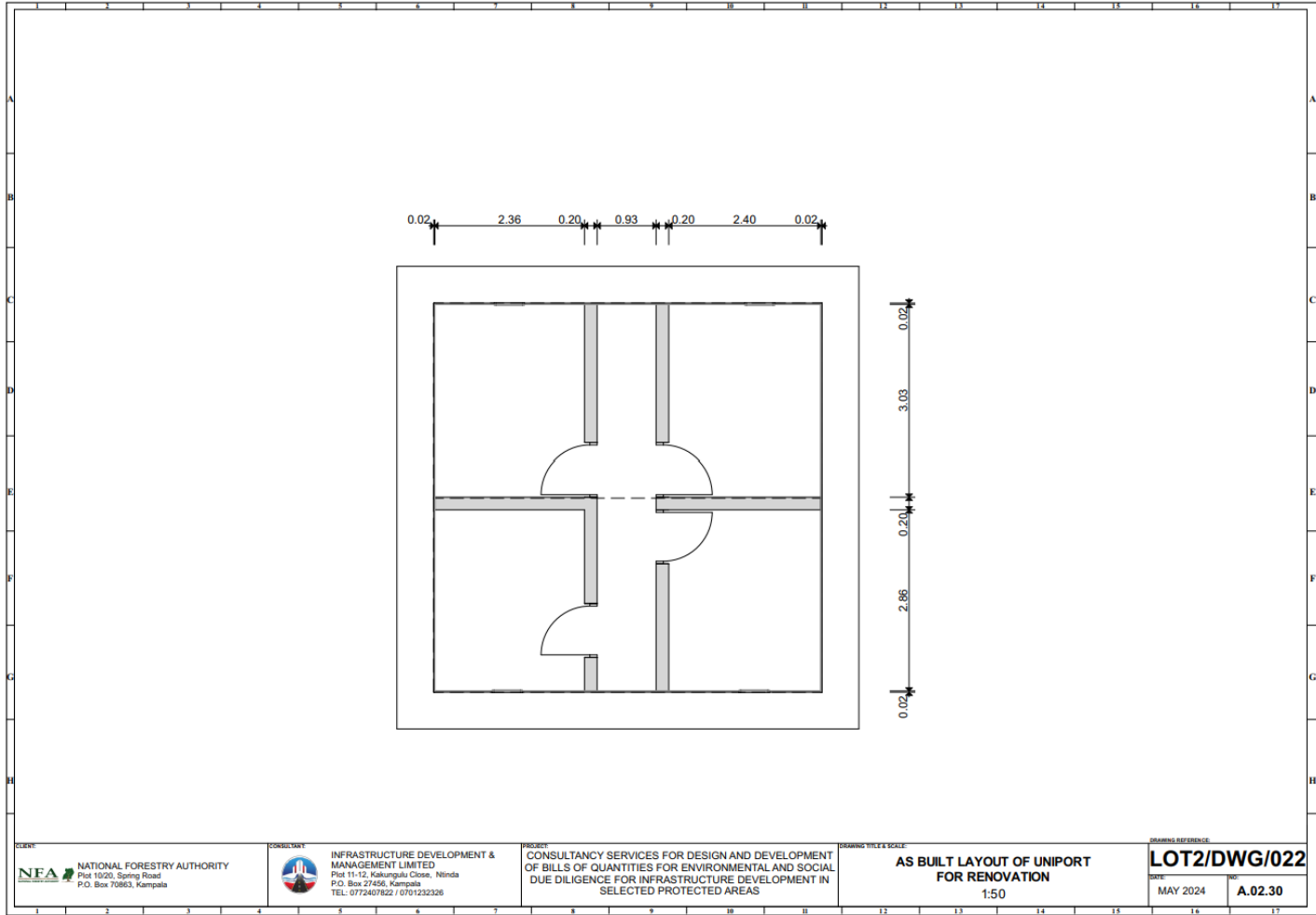
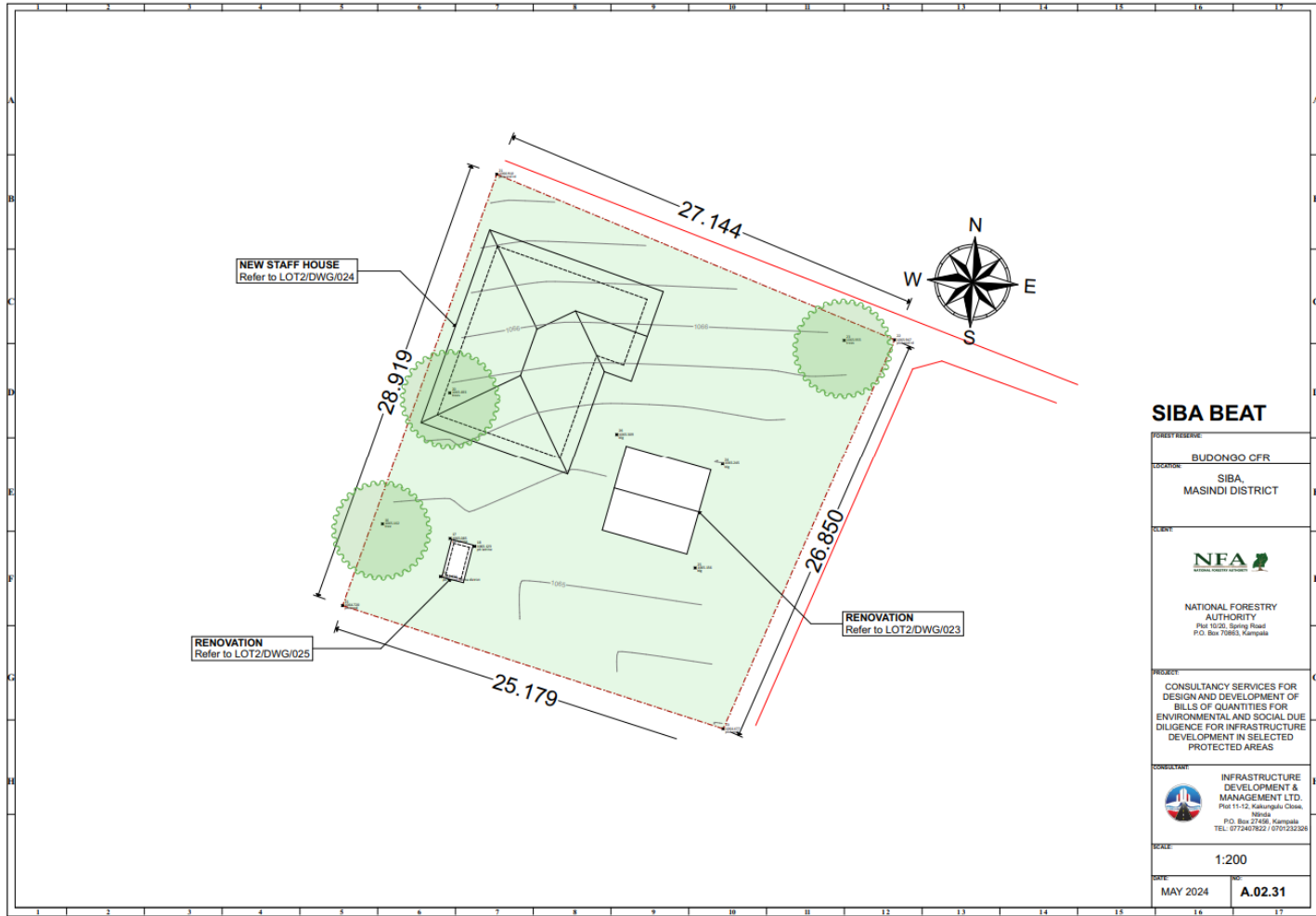

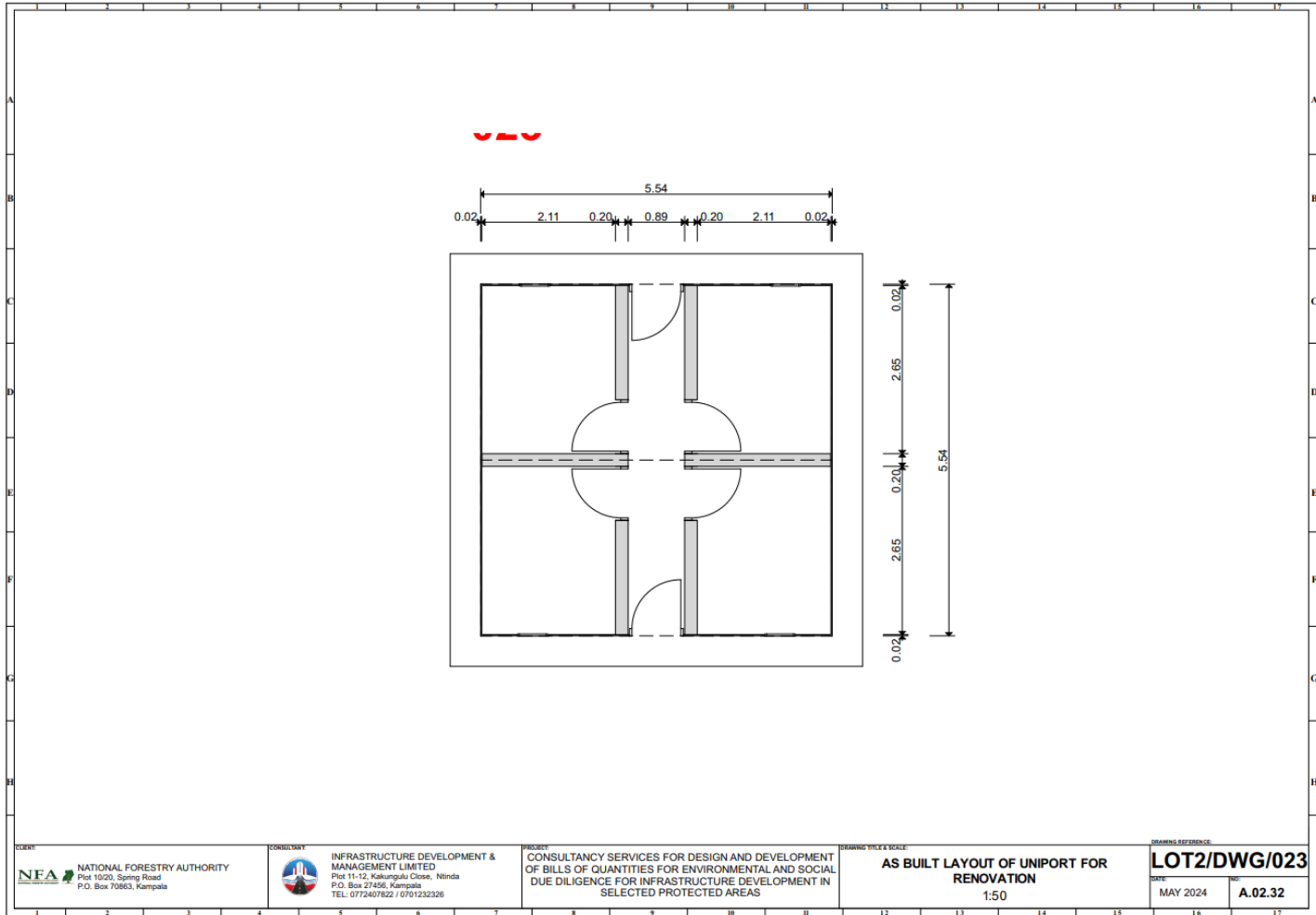

Figure 2.8: Biiso site Renovation drawings



SIBA BEAT

FOREST RESERVE:	BUDONGO CFR
LOCATION:	SIBA, MASINDI DISTRICT
CLIENT:	 NATIONAL FORESTRY AUTHORITY Plot 10/20, Spring Road P.O. Box 70863, Kampala
PROJECT:	CONSULTANCY SERVICES FOR DESIGN AND DEVELOPMENT OF BILLS OF QUANTITIES FOR ENVIRONMENTAL AND SOCIAL DUE DILIGENCE FOR INFRASTRUCTURE DEVELOPMENT IN SELECTED PROTECTED AREAS
CONSULTANT:	 INFRASTRUCTURE DEVELOPMENT & MANAGEMENT LTD. Plot 11-12, Kalungula Circle, Nansole, P.O. Box 27458, Kampala TEL: 0772467822 / 0701232108
SCALE:	1:200
DATE:	MAY 2024
NO.:	A.02.31



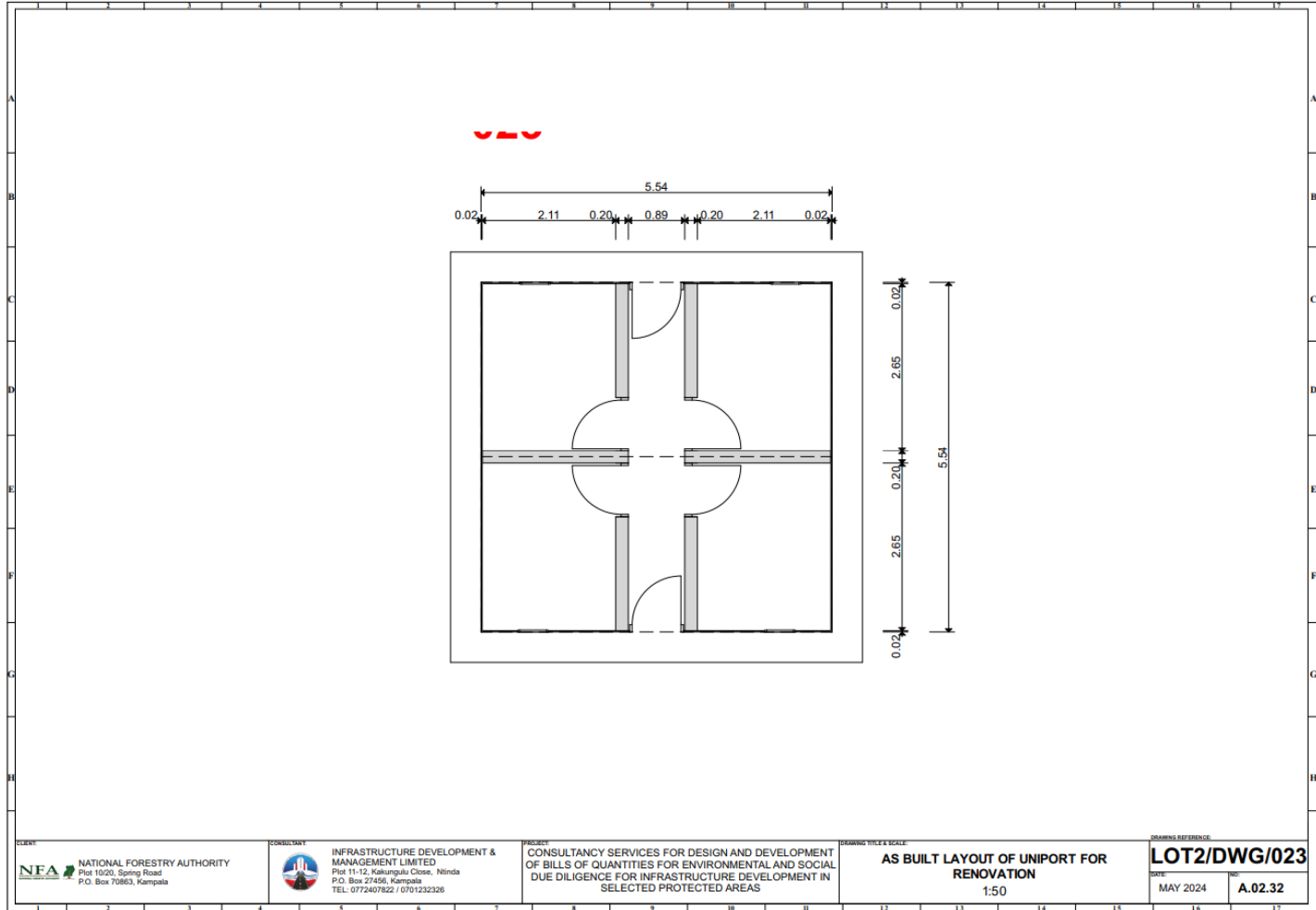

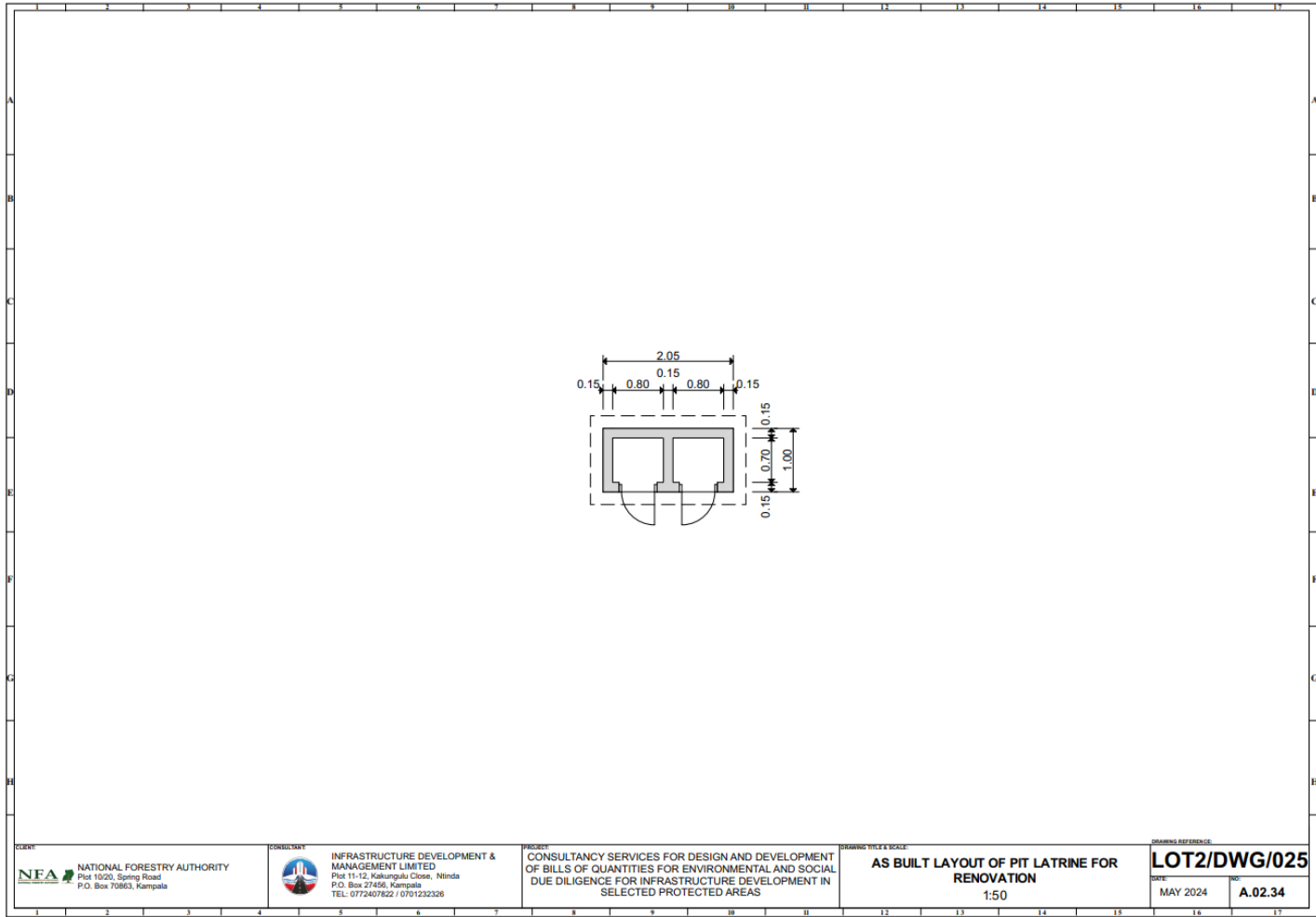
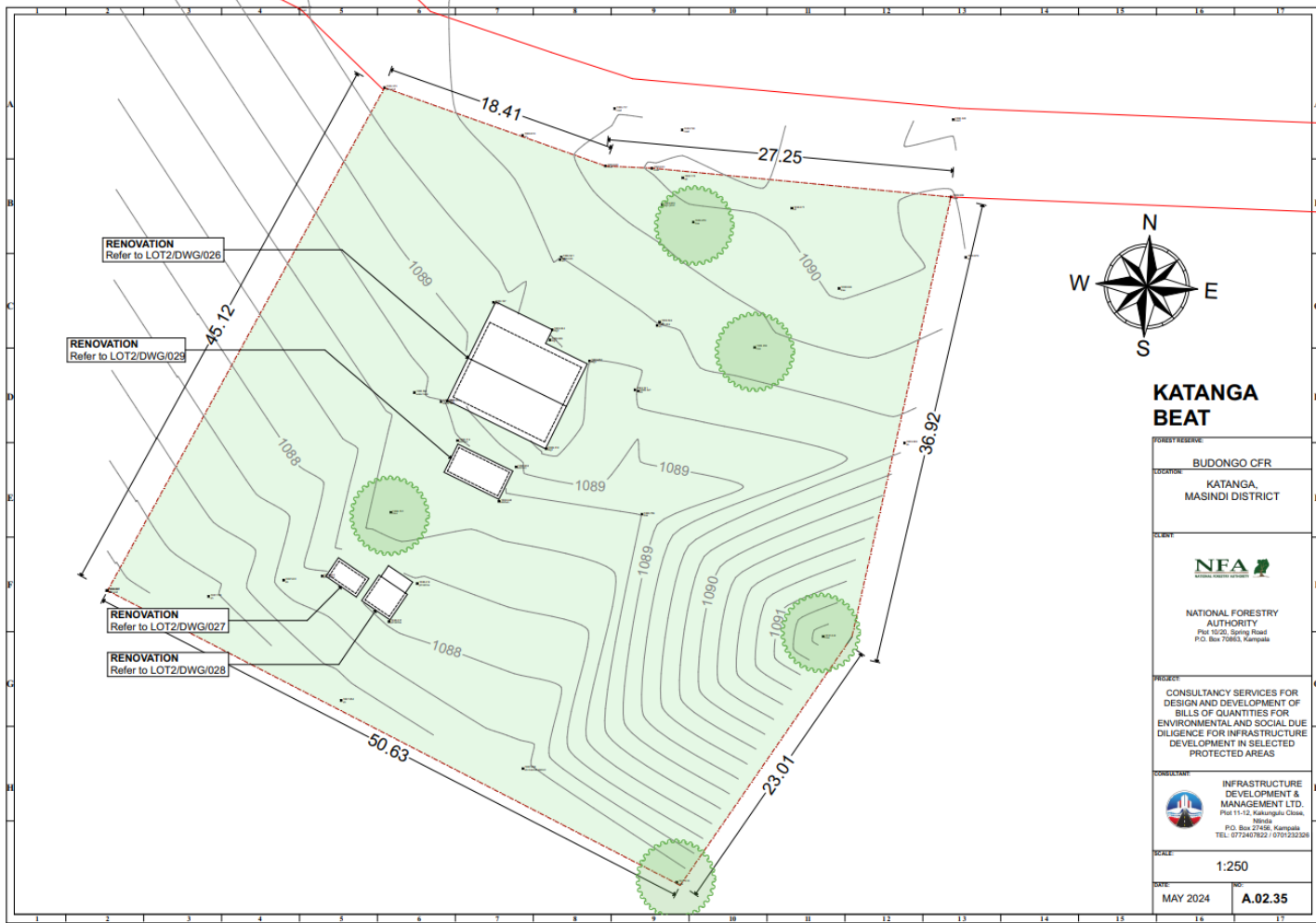
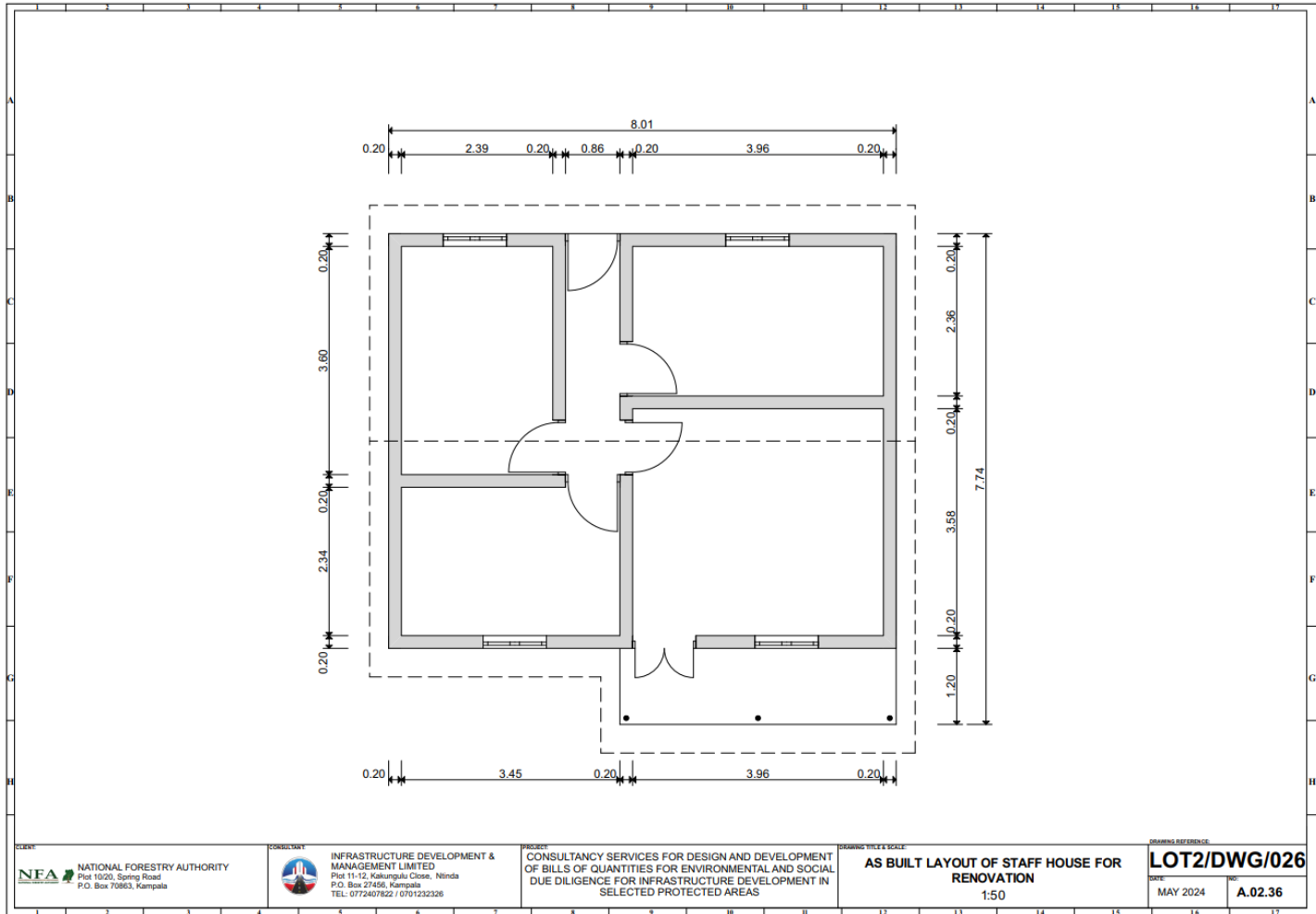
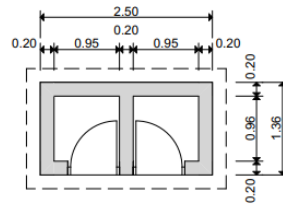

Figure 2.9: Siiba site Renovation drawings







<p>CLIENT</p> <p>NFA NATIONAL FORESTRY AUTHORITY Plot 10/20, Spring Road P.O. Box 70863, Kampala</p>	<p>CONSULTANT</p> <p>INFRASTRUCTURE DEVELOPMENT & MANAGEMENT LIMITED Plot 11-12, Kakungulu Close, Ntinda P.O. Box 27456, Kampala TEL: 0772407822 / 0701232326</p>	<p>PROJECT</p> <p>CONSULTANCY SERVICES FOR DESIGN AND DEVELOPMENT OF BILLS OF QUANTITIES FOR ENVIRONMENTAL AND SOCIAL DUE DILIGENCE FOR INFRASTRUCTURE DEVELOPMENT IN SELECTED PROTECTED AREAS</p>	<p>DRAWING TITLE & SCALE</p> <p>AS BUILT LAYOUT OF PIT LATRINE FOR RENOVATION 1:50</p>	<p>DRAWING REFERENCE</p> <p>LOT2/DWG/027 DATE: MAY 2024 REF: A.02.37</p>
--	---	---	--	---

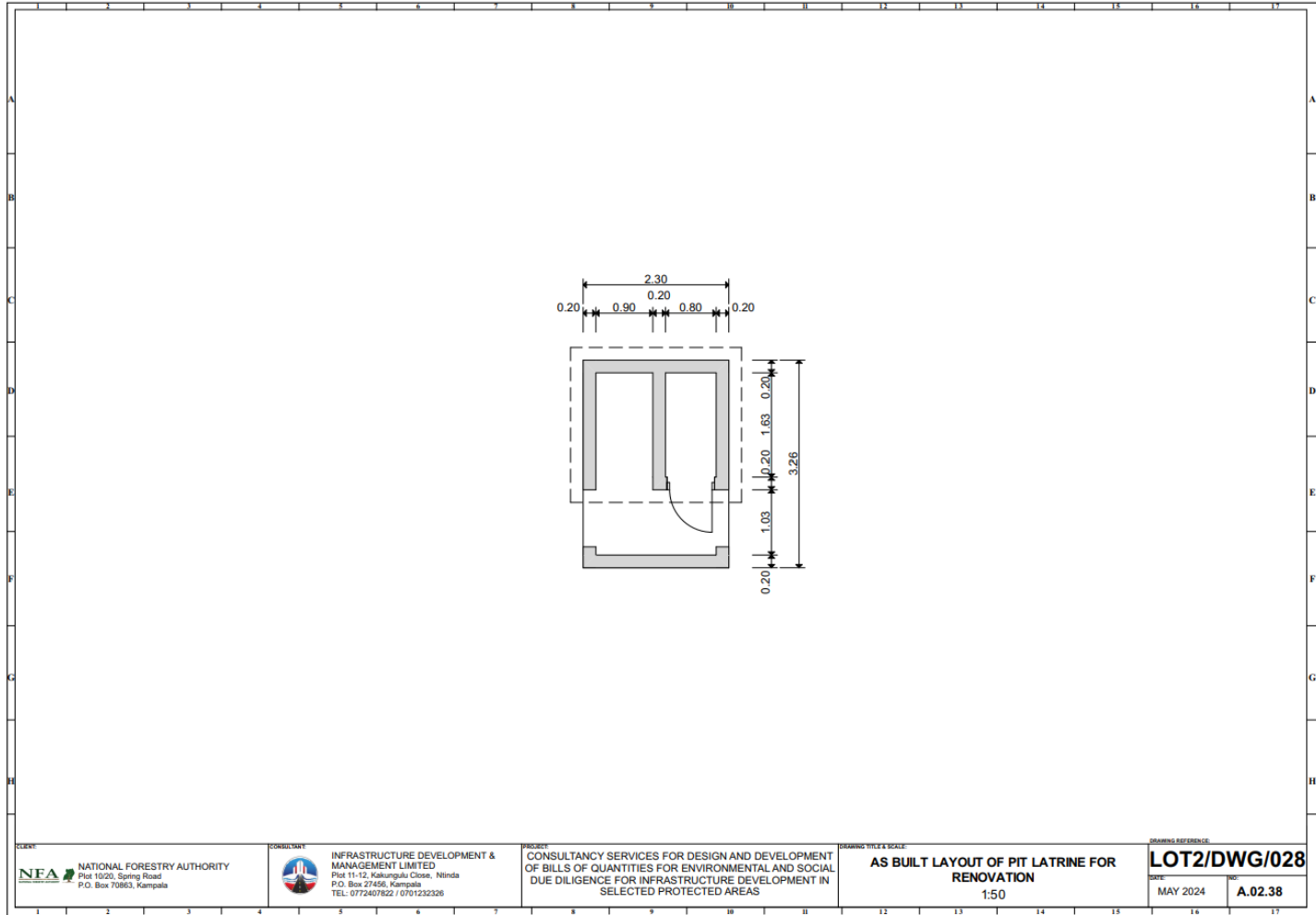

<p>CLIENT</p> <p>NATIONAL FORESTRY AUTHORITY Plot 1020, Spring Road P.O. Box 70863, Kampala</p>	<p>CONSULTANT</p> <p>INFRASTRUCTURE DEVELOPMENT & MANAGEMENT LIMITED Plot 11-12, Kakungulu Close, Ntinda P.O. Box 27456, Kampala TEL: 0772407822 / 0701232326</p>	<p>PROJECT</p> <p>CONSULTANCY SERVICES FOR DESIGN AND DEVELOPMENT OF BILLS OF QUANTITIES FOR ENVIRONMENTAL AND SOCIAL DUE DILIGENCE FOR INFRASTRUCTURE DEVELOPMENT IN SELECTED PROTECTED AREAS</p>	<p>DRAWING TITLE & SCALE</p> <p>AS BUILT LAYOUT OF PIT LATRINE FOR RENOVATION 1:50</p>	<p>DRAWING REFERENCE</p> <p>LOT2/DWG/028</p> <p>DATE: MAY 2024 REV: A.02.38</p>
--	--	---	---	---

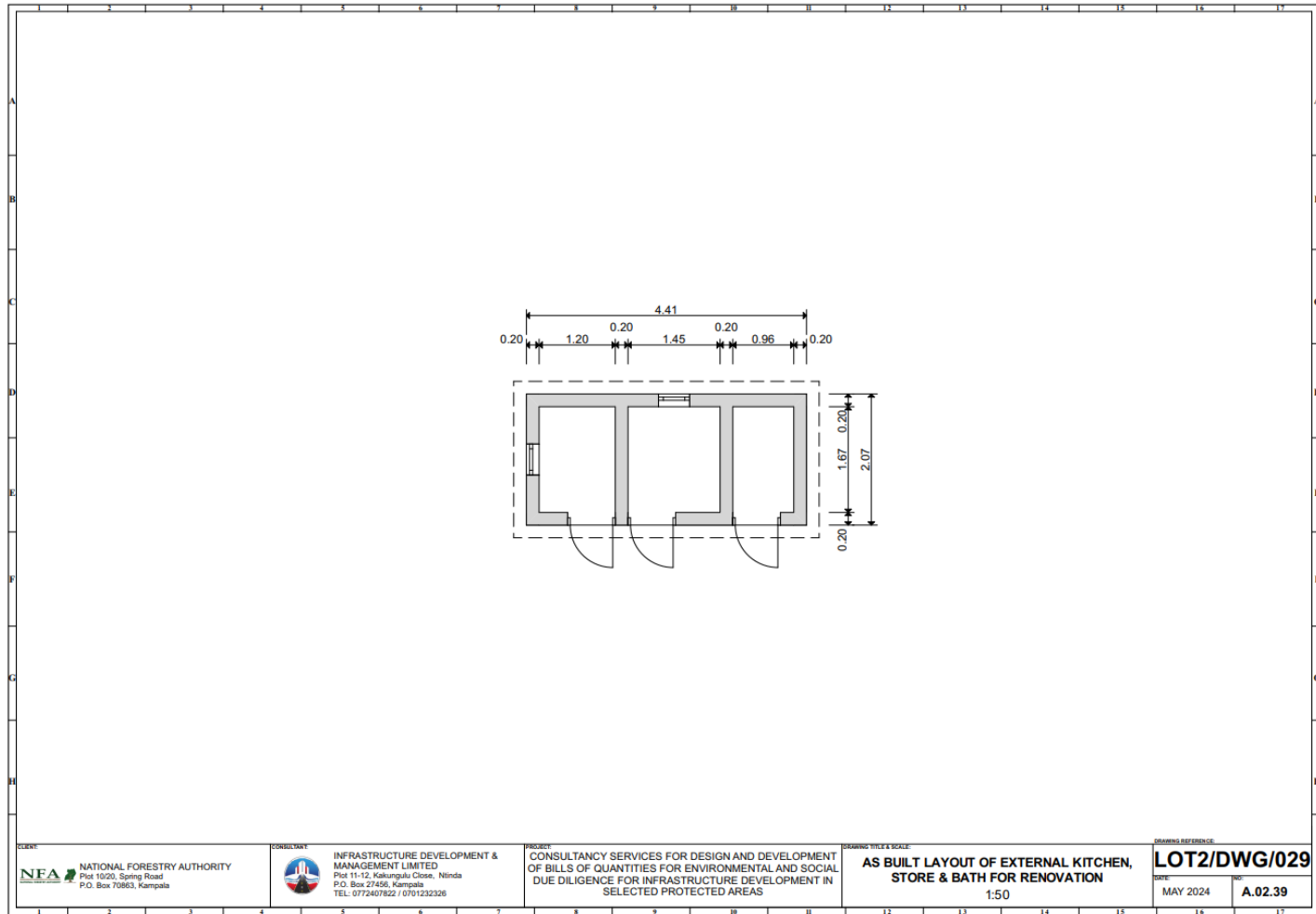

Figure 2.10: Katanga site Renovation drawings

2.3 Renovation phase

The renovation phase of works shall involve renovation of the office and staff housing. The activities to be performed during the renovation for all the sites except Amaply include changing the roof, structural coverings, refurbishing the windows, doors and replacing defective ones, refining the dilapidated ceilings, new floor strides, reconstructing the aprons, repairing the walls by replacing defective plaster with new plaster, installing power supply and fittings, installing rainwater harvest system. For Amaply beat, reconstruction of the entire system is recommended. The foundation cannot support the structure and therefore, a complete reconstruction is recommended.

During this period, workers will be transported onto the respective work sites by the contractor's vehicles or walk from their homes hence no worker will stay on site. Each site will require 6 months for completion, but this will change depending on factors such as funding, resource mobilization, and natural calamities, among others.

2.3.1 Construction inputs and equipment and the environment

The major construction raw materials include sand, cement, stones, crushed rock (including gravel/ballast), steel metals, roofing materials (including iron sheets, timber), rainwater harvesting materials (tanks, pipes, gutters), solar system (solar panels, batteries etc), painting materials, among others, will be obtained from neighboring communities where available.

Construction machinery, including trucks, concrete mixers, tools, and other relevant construction equipment will be used for the transportation of materials and the resulting construction debris.

2.3.2 Project labour

Construction labor force will comprise of both skilled and non-skilled workers. The contractor will be encouraged to get labors from the neighboring community. Furthermore, each site will require 40 workers (70% skilled and 30% unskilled), but this can change when construction work plans are established at the start of the construction phase.

2.3.3 Utilities and Services

These will include.

2.3.3.1 Water supply, sewerage and storm water drainage

For sites within reach of National Water and Sewerage Corporation water and sewerage infrastructure, national water will be installed and rainwater as an alternative and for sites not within the reach, rainwater will be the main source of water. Water during the construction phase will be purchased by the contractor and stored in a temporary onsite water reservoir. All sanitary facilities will be provided and installed by the contractor.

2.3.3.2 Earthing and Lightning Protection

A general system for the earthing will be put in place during the renovation. This will consist of a copper cable bonded to the outer foundation pads. This earthing will later be connected to the incoming power supply. Lightning protection shall consist of a copper tape on top with appropriate down conductors bonded to the general earth with inspection chambers and test points.

2.3.3.3 Energy Sources

During the renovation phase, the main source of electricity will be a mobile generator which will provide energy required to power electric equipment on the sites. Fuel for the generator will be procured from the nearest fuel station. Where necessary, gas will be used for welding metallic sections on site.

2.4 Operation Phase

The operation phase of this project refers to the time after construction has ended and the office and staff building is in use. This phase will involve the use of the office for its intended purpose, and other associated functionalities for the better housing of the NFA staff members. The following issues are deemed significant for the operations phase.

2.4.1 Fire and Emergency

A comprehensive fire safety training and drills for the workforce will be emphasized to all the workers. Serviced fire extinguishers will be placed in strategic locations. Certified electricians will be used during maintenance of electrical component. Emergency contacts will be obtained and will be accessed by all the workers in case of any emergencies.

2.4.2 Energy Use and Supply

For sites within the national electricity grid, electricity will be used as the main source of energy. For sites not within close proximity of national grid, solar power will be used as the primary source of energy. The eco stoves will be adopted since they use solar

power and volcanic stones which will generate a smokeless flame for cooking and heating. For staff houses and office building, 4.68kwp smart package Hybrid power box with stored energy of 37.44kwh or 3120Ah battery No 14 of 250Ahrs working with 12No. Photovoltaic of 300w panels complete with; mppt charge controller, inverter and package capabilities power box or equal approved. Photovoltaic 300w panels complete with; mppt charge controller, inverter and package capabilities power box or equal approved and package capabilities power box or equal approved Eco stoves will be installed in the kitchen. The eco stoves will use Solar Power and volcanic stones which will generate a smokeless flame for cooking and heating

2.4.3 Water and Sanitation

For sites within reach of National Water and Sewerage Corporation water and sewerage infrastructure such as West Waibira, the buildings are already connected to NWSC, national water will be used. However, rainwater harvesting will also be installed as an alternative source of water. The sites will have water borne sanitary facilities. However, the contractor will engage with NFA and the design team to advise on the potential water sources for the construction phase and operation phase and suggest alternative water sources in case the preferred water sources are temporarily unavailable. Ground water reservoirs with capacities of either 10,000 liters or 20,000 liters will be constructed on the site depending on the size with a connection to an elevated tank of 5000 liter to provide adequate storage. The water will then be treated with chlorine to enhance its safety as will be guided in the user manuals at the commissioning of the facilities.

Water-based sanitary facilities will be established at the accommodation sites. Sanitary waste shall be managed by using septic tanks established at the site as onsite wastewater management facilities. These will be routinely managed and emptied using licensed cesspool emptiers once full, who will dispose of the fecal waste/sludge at gazetted sites for disposal of this kind of waste.

The sites will have water purifiers as these will aid in providing portable water for consumption.

2.4.4 Waste Management

The waste that will be generated at the office and staff building will include generally non-hazardous waste such as plastic polythene bags, material packaging bags, food remains, paper, etc. These will be stored in coded waste bins and shall be segregated at source. Municipal waste will be disposed of at the nearest designated Town Council waste disposal site once the collection bins are full.

2.4 Locations Description and Baseline

2.4.1 West Waibira Staff Accommodation Renovation

The site is located at coordinates WGS 1984 UTM Zone 36N: 337421m E, 185153m N in Kyimpunu Village, Nyabyeya Parish, Budongo Sub County, Bungenge County in Masindi District. The site is about 27km to Hoima Town and about 32km to Masindi Town. The site is inside Nyabyeya Forest College and about 2km to Nyabyeya HC 11 and it is easily accessible via the college’s existing road network. There is a nearby borehole about 200m from the site. Nyamagata stream is about 3km along Biso Road. There is also piped water at the site. The community surrounding the site is comprised of Bayoro, Lugbara and Aluru. The major economic activity of the surrounding community is farming, growing mainly sugarcane, cassava, maize, beans and bananas.



Staff housing to be renovated



Office Block



Site dominated by shrubs of Lantana camara and Vernonia amygdalina ***Office for demolition***

Figure 2.11 West Waibira existing components

2.4.2 Amaply site

The site is situated at coordinates WGS 1984 UTM Zone 36N: 354906 m E, 202122m N. The site is in Bokwe Village, Labongo Sub County in Masindi District. The nearest water is the start of River Bokwe about 1km. The site is 800m from Masindi-Pakwach Murchison Falls National Park road and can be accessed through already existing Bokwe Community Road. The nearest Health Centre is Kilanyi HC 11 about 8km from the site. The nearest communities to the site are the Bayonro, Alur, and the Lendo who are major farmers growing mainly cassava and bananas. There is no power source, therefore solar power is recommended.



Site dominated by Imperata cylindrica and a few scattered acacia ssp ***Foundation site***



Engagement with Local leader

Black & white casqued hornbill

Figure 2.12: Amaply site existing components

2.4.3 Hanga site

The site is situated at coordinates WGS 1984 UTM Zone 36N: 354042m E, 198903m N along Khaguzi Nyankyanika Road in Kidwera Village, Khaguzi Parish, Rabongo Sub County in Masindi District. The site is 20m from the existing Khaguzi Nyankyanika road. The nearest water source is a borehole about 800m from the site and River Nyamitete (protected well). The nearest health center is Kilai HC 11 about 2km from the site. There is no power source, thus, solar power is recommended.



Unhealthy Latrines



Office block



Tree species; *Ficus elastic*, *Delonix regia* and *Erythrina abyssinica*

Staff housing

Figure 2.13: Hanga site existing components

2.4.4 Kabalye site

The site is situated at coordinates WGS 1984 UTM Zone 36N: 353838m E, 190782m N. in Kabalye village, Karujubu Sub County, Masindi Municipality, Masindi District. This beat is known as a military training ground for officers who occasionally train from there. The electricity connection is about 1km from the site although the existing structures have no power connection. Solar power connection is highly recommended at the site. The site has water reservoir point available although a better water harvesting system is recommended. The site can be accessed through the existing Kabalye road network.



Staff housing



Pine woodlot



Unhealthy latrines



Poor waste disposal

Figure 2.14: Kabalye site existing components

2.4.5 Biiso Renovation

The site is situated at coordinates WGS 1984 UTM Zone 36N: 326055 m E, 192887m N. The site is in Stina Village, Busingiro Parish, Biiso Sub County, in Buliisa District. There is no nearby water source next to the site. The nearest health center is Biiso HC 11 about 2km from the site. There is electricity power at the site and therefore electricity will be the main source of power though solar power will also be installed as a backup. The community around the site are Bagungus and Alur who are majorly farmers. There's an existing access road to the site. The site is 30m along Stina A community road and 500m Hoima-Masindi road.



Office block



Engagement with community members



Cassava garden in front of the office



Water Reservoir

Figure 2.15: Biiso site expected components

2.4.6 Siiba Renovation

The site is situated at coordinates WGS 1984 UTM Zone 36N:315374m E, 183122m N in Siiba Village, Kapapi Parish, Kigorobya Sub County in Hoima District. The nearest water source is Siiba stream about 1km from the site. The nearest Health Centre is Kapapi HC11. The site can be accessed through an existing Kasenene Road and about 30km to Hoima District. There is no power at the site, and therefore solar power is recommended. The surrounding communities are Bagungus and the Aluru's and they are mainly farmers.



One structure used as an office and a staff housing and a Pine woodlots

Figure 2.16: Siiba site expected components

2.4.7 Katanga Renovation

The site is situated at coordinates WGS 1984 UTM Zone 36N: 326897m E, 178382m N in Katanga Village, Nyatonzi Parish and Sub County in Masindi District. The site is 10m along Katanga road network and can be accessed through the same road. The nearest water source is Waki Stream and a borehole is about 500m from the site. The nearest Health facility is Nyatonzi HC 111. The nearest tribes around the site are the Banyoro and the Lugbara and they are mainly farmers. There is electricity power at the site and therefore electricity will be the main source of power though it will be backed up by solar power.



Office Housing



Signage



Engagement with neighbour



Persea americana and Biden pilosa

Figure 2.17: Katanga site expected components

2.4.8 Nyakafunjo Beat

Nyakafunjo beat is located in Nyakafunjo Village in Nyabyeya Parish, in Budongo Sub County, Masindi District. It lies at coordinates WGS 1984 UTM Zone 36N: 187909m N, 337312m E at an elevation of 1096 m above sea level. There is an existing accessible road to the site through Nyabyeya-Nyakafunjo community road. It is found in a low-lying area with sandy clay soils. The site also has no power connection nearby hence a reliable solar system is recommended. The site is close to a nearby borehole which is the main source of water in the area, about 200m away from the site. A reliable water harvest system is recommended to be installed for the renovated office and staff house.



Office Block



Closed canopy forest dominated by Kaya spp , Meosopsis emini, Ficus spp surrounded by grasses of Imperata cylindrica

Figure 2.18: Nyakafunjo beat existing components

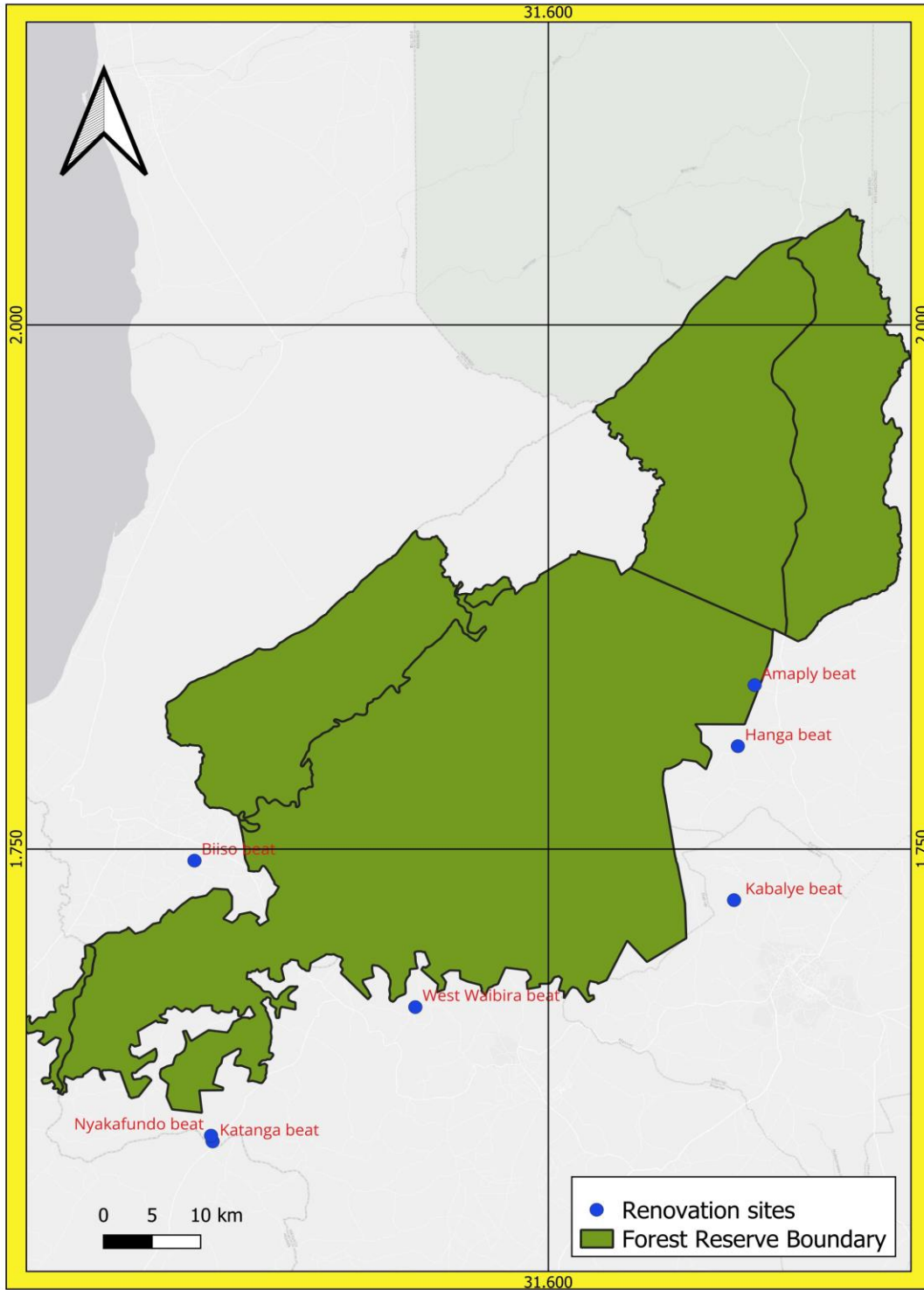

Figure 2.19: Location of the proposed sites

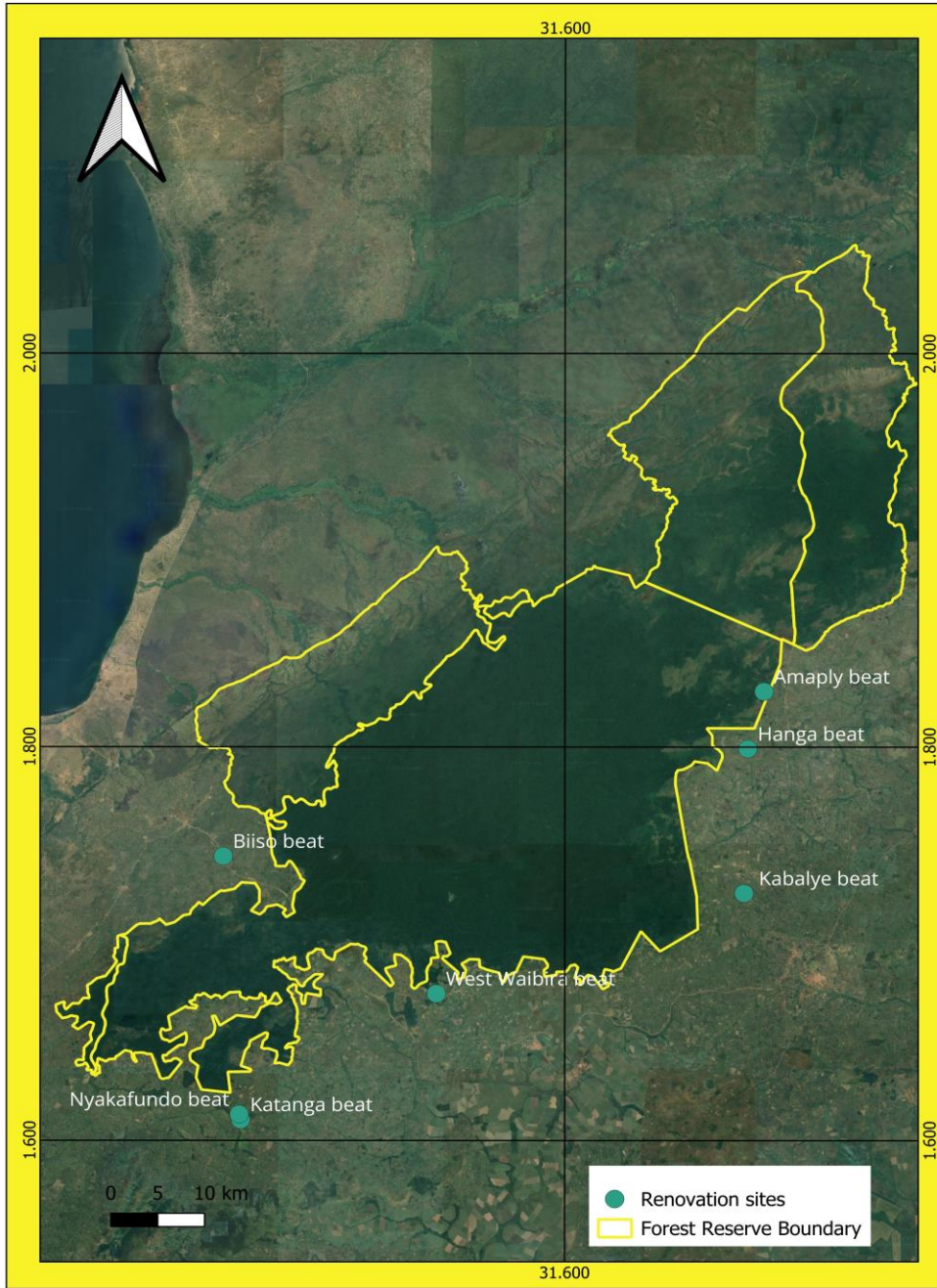

Figure 2.20: Google view of the proposed sites

2.5 Biological Baseline description of Budongo CFR

2.5.1 Flora

Budongo Central Forest Reserve boasts of a complex mosaic of vegetation types, ranging from dense, closed canopy forests to open savannahs and riverine forests as described below;

2.5.1.1 Closed canopy forests

These are the primary forests that dominate Budongo, characterized by a dense canopy formed by tall, mature trees. The canopy layer in these forests is often closed allowing very little light to penetrate to the forest floor. This type of forest is home to a wide variety of flora and fauna, including mahogany trees (*Khaya* spp.), ironwood (*Cynometra alexandri*), and various species of figs (*Ficus* spp.)

2.5.1.2 Colonizing forests

These forests are areas that are in the process of regenerating after disturbances such as logging or natural events. Colonizing forests are characterized by a mix of pioneer species that are adapted to open and disturbed habitats. These species are typically fast-growing and include *Albizia* spp. and other light-demanding trees.

2.5.1.3 Mixed forest

This consists of a variety of tree species, including mahogany, fig trees, among others. These forests are highly diverse and provide habitat for numerous species of wildlife. The structure of mixed forests includes multiple layers: emergent trees, canopy trees, understory trees, shrubs, and herbaceous plants

2.5.1.4 Swamp and riverine forests

Budongo also contains areas of swamp and riverine forests, which are found along watercourses and in areas with poor drainage. These forests are dominated by water-tolerant species such as papyrus, raffia palms (*Raphia farinifera*) and swamp mahogany (*Guibourtia* spp.)

2.5.1.5 Savannah woodland and grassland

The forest also includes patches of savannah and woodland, especially on the forest's fringes. These areas are characterized by a mix of grasses and scattered trees and shrubs. Species commonly found in these habitats include *Acacia* spp. and various grasses.

2.5.2 Fauna

The different vegetation types provide habitats for several fauna species. The forest is highly rich in biodiversity with over 360 birds, 289 butterflies and 24 mammal species. The great abundance of the large East African Mahogany trees also harbours several primates including chimpanzees, black and white... red-tailed monkeys, olive baboons, and some nocturnal primates including galagoes.

The forest harbours the endemic black-headed paradise flycatcher and Puvel's Illadopses, among other bird species (Chocolate-backed Kingfisher, Chestnut Crowned Eremomera, Dusky long-tailed Cuckoo, Yellow-browed Camaroptera, Forest Robin, White-spotted Flufftail, Yellow and Grey Longbill, and Little Green Sunbird)

2.6 Physical Characteristics of Budongo Central Forest Reserve

2.6.1 Climatic patterns

2.6.1.1 Rainfall patterns

Budongo Central Forest Reserve experiences a tropical rainforest climate characterized by high humidity and plentiful rainfall year-round. Rainfall patterns exhibit two primary seasons: the long rainy season stretching from March to May, with April marking the peak of precipitation, featuring heavy downpours; and the short rainy season occurring between September and November, with October being the peak month, characterized by frequent rain showers akin to those in the long rainy season.

2.6.2 Soils and Geology

The soils and geology of Budongo Central Forest Reserve play pivotal roles in shaping its ecological landscape. The reserve's soils are predominantly derived from ancient

crystalline rocks and volcanic formations, contributing to diverse soil types such as lateritic soils and clayey soils. These soils typically exhibit a high level of fertility, fostering the growth of a rich and diverse flora within the forest. Additionally, the geology of the area is characterized by a mixture of metamorphic and igneous rocks, which have undergone extensive weathering processes over millennia, further enriching the soil composition. This geological diversity contributes to the unique biodiversity and ecological significance of Budongo Central Forest Reserve, making it a vital habitat for numerous plant and animal species.

2.7 Biophysical Characteristics of the Sites

2.7.1 Noise Assessment

Noise levels at the renovation sites were measured using a Casella Cel 621C2/K1 integrating 1/3 octave band sound level meter (Class 2) and compared against the National Environment Noise Standards (2003) and World Bank EHS Guidelines (2007). Baseline results showed that noise levels were below the permissible limits at 75 dB(A) for daytime and 65 dB(A) for nighttime at all sites. Renovation activities are expected to temporarily increase noise levels from construction tools, traffic, and worker activities, impacting local communities, workers, and wildlife. These noise increments could temporarily affect local communities, workers, and wildlife. However, the impact will be managed through effective noise mitigation strategies and monitoring.

Table 2-1: Baseline Noise Results for Renovation Sites

Project activity	GPS Coordinates (UTM 36N)	Noise results			Noise source	Noise receptor
		Min (db)	Av (db)	Max (db)		
Nyakafundu Office	1887909 m E, 187909m N	21	41	51	<ul style="list-style-type: none"> • Community • School • Birds • Traffic 	<ul style="list-style-type: none"> • School • community
Nyakafundu	1887909 m E,	21	41	51	<ul style="list-style-type: none"> • Community 	<ul style="list-style-type: none"> • School

staff housing	187909m N				<ul style="list-style-type: none"> • School • Birds • Traffic 	<ul style="list-style-type: none"> • community
Amaply	354906mE, 202122mN	32	48	52	<ul style="list-style-type: none"> • Birds • Community 	<ul style="list-style-type: none"> • Community
Hanga site	326977m E, 178076m N	32	48	52	<ul style="list-style-type: none"> • Birds • Community 	<ul style="list-style-type: none"> • Community
Kabalye site	353838m E 190782m N	18	43	50	<ul style="list-style-type: none"> • Birds • Community 	<ul style="list-style-type: none"> • Community
Biiso renovation	326055 m E, 192887m N	27	46	52	<ul style="list-style-type: none"> • Traffic • Community 	<ul style="list-style-type: none"> • Community
Siiba renovation	315374m E, 183122m N	23	42	62	<ul style="list-style-type: none"> • Traffic • Community 	<ul style="list-style-type: none"> • Community
Katanga renovation	326897m E, 178382m N	19	36	48	<ul style="list-style-type: none"> • Minimal traffic • Community 	<ul style="list-style-type: none"> • Community
Standard of noise limits <ul style="list-style-type: none"> • Construction site day 75 night 65 						

2.7.2 Air Quality

The baseline ambient air quality parameters of the sites were obtained using a MX 60 multi-gas and the results are shown in Table 2-2 below. The results indicate that pollutant levels fall within the permissible limits defined by both the National

Environment (Air Quality Standards) Regulations 2024 and the World Bank EHS Guidelines (2007), and this means that the air quality can be considered favorable for the local wildlife ecosystem. However, the renovation activities such as construction, demolition, and material transport could potentially increase the levels of dust (PM10, PM2.5) and gaseous pollutants (NO₂, CO, SO₂) at the site. The impact could result in short-term deterioration of air quality, which may affect both human health and wildlife if not properly managed.

Table 2-2: The Air quality Baseline Results for the renovation sites

Site name	AQI	PM 2.5 µm	PM10 µm	Source	Receptor
Nyakafundu Office	32	10	10	Dusty road	<ul style="list-style-type: none"> • Community • School
Nyakafundu staff housing	32	10	10	Dusty road	<ul style="list-style-type: none"> • Community • School
Amaply	53	13	16	Dusty road	<ul style="list-style-type: none"> • Community
Hanga site	53	13	16	Dusty road	<ul style="list-style-type: none"> • Community
Kabalye site	48	12	18	Dusty murram road	<ul style="list-style-type: none"> • Community
Biiso renovation	42	7	11	Dusty murram road	<ul style="list-style-type: none"> • Community
Siiba renovation	46	9	12	Dusty murram road	<ul style="list-style-type: none"> • Community
Katanga renovation	20	4	5	Dusty murram road	<ul style="list-style-type: none"> • Community

2.7.3 Flora and Fauna

2.7.3.1 Nyakafunjo site

The Nakafunjo site is an open field of grasses surrounded by herbaceous plants and a savanna woodland dominated by acacia spp, *Broussonetia papyrifera*, *kaya* ssp. *Ficus elastica* and *Measopsis emini*. The grasses are dominated by *Cynodon dactylon*, *Solanum incanum* and *Elymus repens*, interspersed with sporadic herbs of *Ocimum lamiifolium*, *Bidens pilosa* and *Cymbopogon*.

The recorded avian species include the Great blue turaco (*Corythaeola cristata*), White throated bee-eater (*Merops albicollis*), Buff –throated apalis (*Apalis rufogularis*), Common bulbul (*Pyconotus barbatus*), Scarlet chested sunbill (*Chalcomitra senegalensis*), Ring-necked dove (*Streptopeliacapicola*) among others.

2.7.3.1.1 Conservation status of the recorded species

All the plant species recorded except for *Khaya anthotheca* are considered of least concern under the IUCN red list of 2024. *Khaya anthotheca* is considered Vulnerable under the IUCN redlist 2024. Furthermore, all the recorded avian species are of least concern.

2.7.3.1.2 Protected tree species

According to the National Forestry and Tree Planting Regulations 2016, only one protected tree species of *Ficus elastica* was recorded at Nyakafunjo site.

2.7.3.2 Biiso

The site is typically a settlement area with roadside cultivated crop gardens of mainly cassava, maize and beans. The observed plant and tree species include *mangifera indica*, *jacalanda mimosfolia*, *Makhamia lutea*, *Artocarpus heterophylla* and *Senna spectabilis* with grasses including mainly *Bidens pilosa* and *Targetes minuta*.

The recorded avian species include Common bulbul (*Pyconotus barbatus*), Black-necked weaver (*Ploceus nigricollis*), Rupells starling (*Lamprotornis purpuroptera*),

African pied wagtail (*Motacilla aguimp*), Little greenbul (*Eurillas virens*), White spotted flufftail (*Sarothrura pulchra*), Eastern plantain eater (*Crinifer zoronus*) among others.

2.7.3.2.1 Conservation status of the recorded species

All the recorded flora and avian species are of least concern as per the IUCN red list of 2024

2.7.3.2.2 Protected tree species

Mangifera indica

2.7.3.3 West Waibira

The site is an herbaceous dominated site within a modified settlement area. The most predominant species being *lantana camara*, *solanum nigrum*, *solanum erianthum*, *sena occidentalis* and *cida acuta*. The tree species observed within and the surrounding of the site include *kaya* spp, *Ficus natalensis*, *Measopsis emini*, *cassia leptopylla*, *Spathodea campanulata*, *mangifera indica*, *Artocarpus heterophylla*, *Grevellia robusta*, *Shirakiopsis elleptica*, *Broussonetia papyrifera* and *acasia hocki* among others.

The recorded avian species include the Lesser striped swallow (*Cecropis abyssinica*), African firefinch (*Lagonosticta rubricate*), Black & white casqued hornbill (*Bycanitstes subcylindricus*), Sulphur breasted bush shrike (*Chlorophoneus silphureopectus*), Collard sunbill (*Antheptes collaris*), Buff –throated apalis (*Apalis rufogularis*), Shining blue kingfisher (*Alcedo quadribrachys*), Hadada ibis (*Bostrychia hagedash*) among others

2.7.3.3.1 Conservation status of the recorded species

All the plant species recorded except for *Khaya anthotheca* are considered of least concern under the IUCN red list of 2024. *Khaya anthotheca* is considered Vulnerable under the IUCN redlist 2024. Furthermore, all the recorded avian species are of least concern

2.7.3.3.2 Protected tree species

Ficus natalensis, *Measopsis emini*, *Mangifera indica*

2.7.3.4 Amaply

It is a formerly cleared ground with the regrowth of mainly shrubs and herbs within a savannah woodland vegetation. The area is dominated by *Lantana camara*, *Cida acuta*, *Imperata cylindrica*, *Erythrina abyssinica*, *Ocimum lamiifolium*, *Elymus repens* and *Acanthus pubescens* with scattered trees *acacia* spp.

The recorded avian species include Woodland kingfisher (*Halcyon senegalensis*), Emerald cuckoo (*Chrysococcyx cepreus*), Common bulbul (*Pyconotus barbatus*), Spectacled weaver (*Ploceus ocularis*), Papyrus yellow warbler (*Calamonastides gracilirostris*) among others.

2.7.3.4.1 Conservation status of the recorded species

All the recorded flora and avian species are of least concern as per the IUCN red list of 2024

2.7.3.4.2 Protected tree species

No protected tree species was recorded

2.7.3.5 Hanga

Hanga site is a settlement area surrounded by croplands of mainly beans and maize in which a few compound and hedge trees were observed. The recorded flora included *Terminalia superba*, *Cypressus* spp, *Pinus pinus*, *Erythrina abyssinica*, *Ficus natalensis*, *Albizia zigia*, *Vernonia amygdalina*, *Pennisetum purpureum*, *Mangifera indica* and *Shirakiopsis indica*.

The recorded avian species include the red checked cordonbleu (*uraeginthus bangalus*), red billed firefich (*lagonosticta senegala*), Yellow-streaked greenbul (*Phyllastrephus flavostriatus*), long crested eagle (*Lophaetus occipitalis*), Common bulbul (*Pyconotus barbatus*), vinaceous dove (*streptopelia vinacea*), village weaver (*ploceus cucullatus*) among others

2.7.3.5.1 Conservation status of the recorded species

All the recorded flora and avian species are of least concern as per the IUCN red list of 2024

2.7.3.5.2 Protected tree species

Albizia zigia, Ficus natalensis, Mangifera indica

2.7.3.6 Kabalye Beat

Kabalye site is adjacent to pine woodlots surrounded by the sugarcane plantation. The site is dominated by hedge and compound trees such as *Cypressus ssp, Pinus pinus, Grevelia robusta, Mangifera indica, Persia americana, Psidium guajava, Ficus natalensis,* and *Callistemon citrus*. The recorded shrubs and grasses include; *Lantana camara, Ocimum lamiifolium, Paspalum notatum, Bidens pilosa* among others.

The recorded avian species include fork tailed drago (*dicrurus adsimilis*), Eastern plantain eater (*Crinifer zoronus*), red billed firefich (*Iagonosticta senegala*), Shining blue kingfisher (*Alcedo quadibrachys*), Common bulbul (*Pyconotus barbatus*) among others.

2.7.3.6.1 Conservation status of the recorded species

All the recorded flora and avian species are of least concern as per the IUCN red list of 2024

2.7.3.6.2 Protected tree species

Ficus natalensis

2.7.3.7 Siiba

Siiba site is dominated by pine woodlot surrounded by a few trees of *Terminalia catappa, Grevelia robusta, Makhamia lutea, Mangifera indica, Persia Americana* and a few crop gardens of mainly cassava and beans.

The recorded avian species include Common bulbul (*Pyconotus barbatus*), western cattle egret (*Bulbus ibis*), Hadada Ibis (*Bostrychia hagedash*), Ring-necked dove (*Streptopeliacapicola*), Lesser striped swallow (*Cecropis abyssinica*) among others

2.7.3.7.1 Conservation status of the recorded species

All the recorded flora and avian species are of least concern as per the IUCN red list of 2024

2.7.3.7.2 Protected tree species

Mangifera indica

2.7.3.8 Katanga

Katanga site is a typical settlement area surrounded by tree crops of *Artocarpus heterophylla*, *Persia Americana*. The other recorded flora species include, *pinus pinus*, *Terminalia superba*, *Terminalia catapa*, *Eucalyptus Grandis*, *Kaya ssp*, *Jacalanda mimisfolia*, *Senna spectabilis*, *Mimosa pudica*, *Cida acuta*, *Cynodon dactylon*, *Solanum incanum*, *Bisens pilosa* and *Elymus repens*. Crop gardens were also observed such as banana plantations and maize.

The recorded bird species include the Eastern plantain eater (*Crinifer zoronus*), village weaver (*ploceus cucullatus*), Hadada Ibis (*Bostrychia hagedash*), Black & white casqued hornbill (*Bycanitstes subcylindricus*) and Common bulbul (*Pyconotus barbatus*)

2.7.3.8.1 Conservation status of the recorded species

All the plant species recorded except for *Jacalanda mimisfolia* are considered of least concern under the IUCN red list of 2024. *Jacalanda mimisfolia* is considered Vulnerable under the IUCN redlist 2024. Furthermore, all the recorded avian species are of least concern.

2.7.3.8.2 Protected tree species

No protected tree species was recorded.

2.7.4 Fauna

The proposed sites harbor a variety of avian species. The recorded bird species include the following; the lesser striped swallow(*Cecropis abyssinica*), Black & white casqued hornbill(*Bycanitstes subcylindricus*), Great blue turaco(*Corythaeola cristata*), Shining blue kingfisher(*Alcedo quadribrachys*), Black-headed weaver(*Ploceus cucullatus*), Eastern plantain eater(*Crinifer zoronus*), African pied wagtail(*Motacilla aguimp*), Rupells starling(*Lamprotornis purpuroptera*), African firefinch(*Lagonosticta rubricate*), Yellow-streaked greenbul(*Phyllastrephus flavostriatus*), Buff –throated apalis(*Apalis rufogularis*), White spotted flufftail(*Sarothrura pulchra*), Collard sunbill(*Anthreptes collaris*), Common bulbul(*Pyconotus barbatus*) among others

The recorded mammal species include; Black & white colobus monkey (*colobus*), Red-tailed monkey (*Cercopithecus ascanius*), Olive baboons (*Papio Anubis*) and chimpanzee (*Pan troglodytes*).

3 POLICY, LEGAL AND REGULATORY FRAMEWORK

3.1 National Policies

3.1.1 The National Environment Management Policy, 1994

The overall goal of the National Environment Management Policy (NEMP) is sustainable social and economic development, which maintains or enhances environmental quality and resource productivity on a long-term basis that meets the needs of the present generations without compromising the ability of future generations to meet their own needs. Section 4.8 requires that an environmental assessment is done for any development project that is likely to have significant impacts on the environment.

This ESMP has been prepared to ensure sustainable development, as the sub-project is likely to result in environmental impacts and risks.

3.1.2 The National Forestry Policy, 2001

This policy provides a framework for the sustainable management, conservation, and development of Uganda's forest resources. Its mandate focuses on ensuring that forests are managed in a way that balances environmental, social, and economic benefits for present and future generations. The policy promotes the conservation of biodiversity, the protection of water catchments, and the sustainable use of forest products. Section 4.1 outlines the policy's commitment to conserving forest ecosystems by emphasizing protection of natural forests, biodiversity conservation and sustainable use of forest resources.

This ESMP has been prepared to ensure the project activities are carried in line with the requirements of this policy.

3.1.3 Uganda Wildlife Policy, 2014

The Wildlife Policy states the intention and the strategic direction of the Government of Uganda regarding wildlife conservation.

Subsection (h) mandates the relevant institution to establish standards, guidelines and mitigation measures to be followed for any development activities that may have a significant impact on wildlife.

NFA should restrict excavation works to areas that will be required for renovation of the sub-project to minimize the impacts on wildlife.

3.1.4 Uganda National Climate Change Policy, 2015

This policy is designed to guide the country in addressing the challenges posed by climate change through strategic adaptation and mitigation efforts. Its general mandate is to integrate climate change considerations into national development planning, ensuring that all sectors contribute to reducing vulnerability to climate change impacts and lowering greenhouse gas emissions. The policy aims to enhance the resilience of communities, ecosystems, and economies while promoting sustainable development practices that align with Uganda's commitment to international climate agreements. Section 3.1 calls for Climate Change Adaptation and Mitigation by Promoting strategies to adapt to the impacts of climate change, especially in sensitive ecosystems like forests. Section 5.1 emphasizes the need to integrate climate change considerations into all development projects.

NFA shall ensure the project contributes positively to climate change adaptation and mitigation while maintaining the ecological balance within Budongo CFR.

3.1.5 The National Land Use Policy, 2007

The overall goal for the national land use policy is "To achieve sustainable and equitable socio-economic development through optimal land management and utilization in Uganda". The client bases on some of the specific goals of this policy among others. To promote land use activities that ensure sustainable utilization and management of environmental, natural and cultural resources for national socio-economic development.

Section 4.5 addresses the management and use of land in environmentally fragile areas, such as forests, wetlands, and other protected areas. It calls for need to protect and conserve fragile ecosystems by regulating and controlling activities that could lead to environmental degradation. Furthermore, it noted the criticality of promoting land use practices that are environmentally sustainable, particularly in areas like Budongo CFR, where maintaining ecological balance.

This ESMP is aimed at ensuring the sustainable project development through the implementation of the proposed mitigation measures to conform to this policy while effectively utilizing land resources.

3.1.6 The National Gender Policy, 2007

The policy provides a legitimate point of reference for addressing gender inequalities at all levels of government and by all stakeholders. The major aspects of this policy provisions include among others;

- Increased awareness of gender as a development concern among policymakers and implementers at all levels;
- Influencing national, sectoral and local government programmes to address gender issues;
- Strengthened partnerships for the advancement of gender equality and women's empowerment and increased impetus in gender activism.

Based on this policy, NFA and/or the contractor shall take gender issues into account during the construction and particularly through equitable access to the job opportunities available.

3.1.7 The Child Labour Policy, 2006

This policy requires the complete elimination of child labour in all forms by prohibiting the employment of children in work that harms their health, safety, or development. It aims to protect children from exploitation and ensure their right to education and proper development. The policy establishes regulations and enforcement mechanisms to

monitor and prevent child labour, promoting safe and child-friendly environments in all sectors.

Section 3 of the policy prohibits child labour by clearly stipulating the prohibition of employing children in any work that is detrimental to their health, development, or education as well as emphasizing the need for strict adherence to regulations that prevent child labour and requiring mechanisms to monitor and enforce compliance.

NFA will ensure strictly no employment of children at the sub-project following this policy.

3.1.8 Uganda Land Policy, 2013

The Uganda National Land Policy was put in place by the Government in 2013 to streamline land management issues in the country. Its major goal is to ensure efficient, equitable and optimal utilization and management of Uganda's land resources for poverty reduction, wealth creation and overall socio-economic development.

Section 4.9 calls for the management of environmentally sensitive areas including forests, wetlands, and protected areas like Budongo CFR. It emphasizes promoting sustainable land use practices that align with environmental conservation goals, particularly in areas with significant ecological value like Central Forest Reserves.

NFA is developing this ESMP to ensure the ecosystem under its jurisdiction is not deteriorate due to the implementation of the project, by ensuring mechanisms are put in place to manage any potential impacts.

3.2 Legal Framework

3.2.1 The Constitution of the Republic of Uganda, 1995

The constitution in its National Objectives and Directive principle of state policy, objective XIII provides for the protection of natural resources.

Under Article 237 (2) (b) of the Constitution, the Government or Local government is mandated to hold in trust for the people and protect, natural lakes, rivers, wetlands,

forest reserves, game reserves, national Reserves and any land, to be reserved for ecological and touristic purposes for the common good of all citizens.

In observance of the above provisions, all the renovation activities in protected areas must take into consideration environmental concerns and ensure that the natural resources, wildlife in this case, are not adversely affected.

3.2.2 The National Environment Act Cap 181

The National Environment Act is the supreme law of environmental management in Uganda. This act provides for various strategies and tools for environment management, which also includes the Environmental and Social Impact Assessment (ESIA) (Section 113) for projects likely to have significant environmental impacts, and audit (Section 126) for ongoing projects/activities which may significantly affect the environment.

The ESMP has been developed to identify, assess and manage environmental and social risks and impacts as the implementation of the sub-project is likely to have associated negative environmental and social impacts and risks.

3.2.3 The National Forestry and Tree Planting Act 2003

This policy mandates the sustainable management and conservation of Uganda's forest resources by establishing a legal framework for protecting both natural and planted forests. It focuses on maintaining ecological balance and biodiversity, promoting tree planting and afforestation, and regulating the use of forest resources to prevent over-exploitation. Section 5 of the Act deals with the designation and management of forest reserves, including control of activities within forest reserves to prevent degradation and maintain ecological integrity.

NFA shall ensure the construction and operation phases of the sub-projects do not interfere and degrade with forest activities as laid out in this Act.

3.2.4 The Land Act, 1998

Section 43, provides for management and utilization of land in line with the Wildlife Act 2019 and other laws. Section 44 (i) mandates the government or local governments to hold in trust for the people and protect national Reserves, wetlands, and forest reserves among others for ecological and touristic purposes for the common good of the citizens of Uganda.

NFA shall ensure the contractor minimizes as much as possible the land take of their developments so as not to compromise the purpose for which the protected areas were gazetted.

3.2.5 The Uganda Wildlife Act 2019

This Act has a mandate for the protection and conservation of wildlife and their habitats across Uganda. It emphasizes safeguarding wildlife from poaching and illegal trade, promoting sustainable use of wildlife resources, and preserving critical habitats to maintain biodiversity. Additionally, it establishes a regulatory framework and enforcement mechanisms to manage wildlife effectively and address any violations. Section 8 outlines the measures for wildlife conservation and habitat management which is essential for ensuring that the ESMP addresses potential impacts on wildlife and their habitats during the project implementation.

NFA shall ensure that the proposed project activities in the CFR are designed in a way to prevent the loss of wildlife during both the construction and operation phases of the project.

3.2.6 The National Climate Change Act, 2021

This Act establishes a legal framework for addressing climate change in Uganda by mandating comprehensive climate action across all sectors. It focuses on integrating climate change considerations into national planning and development, enhancing resilience to climate impacts, and reducing greenhouse gas emissions. The Act establishes a National Climate Change Council to oversee implementation, sets up

mechanisms for monitoring and reporting climate actions, and promotes the adoption of climate-smart technologies and practices.

Section 10 focuses on climate change adaptation, guiding the incorporation of resilience measures to protect the forest and local communities from climate impacts. Section 12 provides guidelines for implementing emissions reduction strategies, ensuring that construction and renovation activities minimize their carbon footprint. Section 15 emphasizes the need for effective monitoring and reporting of climate actions, which is essential for assessing the ESMP's effectiveness and ensuring compliance with climate goals.

NFA shall integrate climate change considerations to ensure that the project supports national climate goals, enhances resilience, and incorporates effective mitigation and adaptation strategies.

3.2.7 Employment Act, 2006

The Employment Act is the governing legal statutory instrument for the recruitment, contracting, deployment, remuneration, management and compensation of workers. The Act also provides for the freedom of association of workers permitting workers to join labour organizations.

Section 32 states that children under the age of 12 years shall not be employed in any business, undertaking or workplace (32(1)). Subsection 32(2) provides restrictions under which a child under the age of fourteen (14) years may be employed; including for light work under the supervision of an adult aged over eighteen (18) years and the work shall not interfere with the child's education.

This development will require recruitment, contracting, and deployment, especially during the preparation and construction phases, thus this Act will be an important pillar on which the project will be conducted.

3.2.8 The Workers' Compensation Act, 2000

The Workers' Compensation Act outlines responsibilities and obligations for both parties (employer and employee) in guaranteeing the safety and health of the workers. The Act outlines matters of compensation for injuries and accidents as well as the responsibility of employees to take care of their health and safety while on the project.

Section 3 provides provisions on employer liability for work-related injuries while Section 4 outlines compensation entitlements for medical expenses, lost wages, and disability. The Act also details the procedure for filing compensation claims in Section 5 and provides for medical and rehabilitation benefits for injured workers in Section 9. Additionally, Section 12 emphasizes the implementation of safety measures to prevent workplace accidents.

All workers at the sub-project should be provided with adequate PPE that is appropriate to the task they are involved in and ensure that workers use them. A workers' compensation policy should be implemented as stipulated.

3.2.9 The Water Act, Cap 152

The Water Act, Cap 152 of 1995 provides for the management of water in Uganda under the mandate of the Directorate of Water Resources Management (DWRM) in the Ministry of Water and Environment. Section 31, subsection (1) of the Water Act deals with the prohibition of pollution to water.

NFA will ensure that appropriate measures to prevent pollution of underground and surface water sources in the site neighbourhood are implemented.

3.2.10 The Occupational Safety and Health Act, 2006

The Occupational Safety and Health Act of 2006 consolidates, harmonizes and updates the law relating to occupational safety and health and repeals the Factories Act of 1964. It makes provisions for the health, safety, welfare and appropriate training of persons

employed in workplaces. The Act provides for safe access to the workplaces and safe work practices which applies to this project as well.

The Act is applicable in relation to protection of the construction workers against secondary injuries and hazards during execution of their duties or work. NFA and the Contractor will provide for the protection of workers from adverse weather, provision of a clean and healthy work environment, sanitary conveniences, washing facilities, first Aid and facilities for safe drinking water and meals. In summary, this act should be used as a guideline to ensure health and safety of workers is guaranteed. NFA and Contractor should provide PPE to its entire staff.

3.3 Regulations and Standards

3.3.1 The National Environment (Waste Management) Regulations, 2020

These regulations apply to all types of waste (non-hazardous and hazardous) and its storage and eventual disposal. Regulation 12 prohibits the disposal of waste into the environment without adequate treatment at a treatment facility approved by the Lead agency. Regulation 5 emphasizes waste minimization measures by making Cleaner Production a requirement for owners or operators of facilities that generate waste. Production process improvement; product cycle monitoring; and incorporation of environmental concerns in the product lifecycle are some of the requirements.

NFA will ensure that wastes are managed in a way to avoid environmental pollution and public health impact and that wastes are managed and disposed of in an environmentally friendly manner.

3.3.2 National Environment (Environmental and Social Assessment Regulations), 2020

These regulations hold for all projects/activities listed under the fourth and fifth schedule of the National Environment Act, 2019. The regulations state in part III section 10 that, environmental impact studies shall be conducted in accordance with terms of reference developed by the developer in consultation with the Authority and the lead agency and that, the study shall be conducted in accordance with the guidelines adopted by the

Authority in consultation with the lead agency under subsection (8) of section 19 of the National Environment Act. Regulation 16 of these regulations also requires that stakeholder consultations should be carried out while undertaking the Environmental Impact Assessment study.

Therefore, the assessment for the proposed project was conducted in line with the requirements of these Regulations.

3.3.3 The National Forestry and Tree Planting Act, 2016

This Act makes provision for the conservation, management and development of forest resources in Uganda and establishes the National Forestry Authority and a fund for tree planting. The purposes of the Act include the creation of an integrated forest sector, conservation of biological diversity, the devolution of functions and powers in the forest sector and the sustainable development of that sector.

Establishment of the project will support the increase in protection of forest reserves against human activities in line with the objectives of this Act.

3.3.4 The *National Environment (Minimum Standards for Management of Soil Quality Regulations, 2001)*

The act sets guidelines for maintaining and protecting soil quality through sustainable practices. It focuses on preventing soil degradation, controlling pollution from chemicals and waste, and promoting agricultural techniques that preserve soil health. The regulation also includes provisions for monitoring soil conditions, proper waste disposal, and land-use planning to prevent over-exploitation and ensure long-term soil productivity and fertility. It serves as a framework to safeguard soil resources for environmental sustainability and agricultural viability.

Therefore, the renovation project will be conducted in line with the requirements of these Regulations.

3.3.5 The National Environment (Noise and Vibrations Standards and Control) Regulations, 2003.

All noise emitting sources at the project sites must conform to the National Environment (Noise and Vibrations Standards and Control) Regulations, 2003. The Regulations are aimed at ensuring maintenance of a healthy environment for all people in Uganda, the tranquility of their surroundings and their psychological well-being. Part IV, Section 19(1) of the Regulations states that *“the owner of machinery or the owner or occupier of a facility or premises or person responsible for any activity; shall use the best practicable means to ensure that the emission of noise and vibration from that machinery, facility, premises or activity does not exceed the permissible noise levels”*.

The activities at the sites under construction will emit noise; hence, the contractor will put in place measures that will minimize noise emissions and keep them below the national standards. The contractor shall take caution on all equipment and noise generating sources, especially during the construction phase

Maximum Permissible Noise Levels are shown in table 2 below.

Table 3: Maximum Permissible Noise Levels for Construction Site

Facility	Noise limit dB(A) (Leq) Day	Noise limit dB(A) (Leq) Night
1. Any building used as a hospital, convalescence home, home for the elderly, sanatorium and institute of higher learning, conference rooms, public library, environmental or recreational sites	45	35
2. Residential buildings	50	35

Source: *The National Environment (Noise and Vibrations Standards and Control) Regulations, 2003. (Schedule 1)*

Time Frame: Use duration

Day- 6.00 a.m. -10.00 p.m.

Night- 10.00 p.m. - 6.00 a.m.

The Time frame takes into consideration human activity.

3.3.6 National Environment (Air Quality Standards) Regulations, 2024

The renovation activities will cause air emissions which will need to be minimised. The draft National Air Quality Standards provide the following regulatory limits.

Table 4: Regulatory Air Quality Standards for selected Pollutants

Pollutant	Averaging time for ambient air	Standard for ambient air
Saw dust	24 hr	1 mgNm ⁻³
Carbon dioxide (CO ₂)	8 hr	9.0 ppm
Carbon monoxide (CO)	8 hr	9.0 ppm
Hydrocarbons	24 hr	5 mg/m ³
Nitrogen oxides (NO _x)	24 hr1 year arithmetic mean	0.10 ppm
Soot	24 hr	500 µg/Nm ³
Sulphur dioxide (SO ₂)	24 hr	0.15 ppm
Sulphur trioxide (SO ₃)	24 hr	200 µg/Nm ³

Note: ppm = parts per million; “N” in µg/Nm⁻³ connotes normal atmospheric conditions of pressure and temperature (25°C and 1 atmosphere).

Baseline air quality conditions for this site were undertaken and are elaborated in chapter three of this report; they shall form a benchmark for the air quality levels during construction.

3.4 International Treaties and Conventions

3.4.1 Convention on Biological Diversity, 1992

Under the Convention, each contracting party is expected to develop national strategies, plans or programs for the conservation and sustainable use of biological diversity.

The convention was signed by Uganda in 1992 and ratified in 1993. This treaty obliges member states to establish a mechanism of engaging local communities, to share issues arising out of conservation of biological resources and use of indigenous knowledge in the management and conservation of protected areas.

The ESMP has been carried out as a measure to protect biodiversity within the Reserve during construction and operation.

3.4.2 The United Nations Framework Convention on Climate Change (“1992 UNFCCC”)

The objective of the 1992 UNFCCC is to tackle the negative effects of climate change. According to Article 2 of the convention, its stated aim is to stabilize greenhouse gas concentration at a level that allows ecosystems to adapt naturally to climate change so that food production is not threatened, while enabling economic development to proceed in a sustainable manner.

The proposed renovation project will be implemented with utmost consideration to conserve all natural and artificial forests, water systems and the general ecological system in the reserve.

3.4.3 The 1968 African Convention on the Conservation of Nature and Natural Resources

Article II of the convention emphasizes the conservation, utilization, and development of natural resources, such as soil, water, flora, and fauna, based on scientific principles and the best interests of the people. Article IV mandates contracting States to combat soil erosion and misuse through effective land-use planning grounded in ecological, economic, and sociological investigations.

The proposed renovation project will be implemented with utmost consideration to conserve flora, fauna, and endangered species in the reserve.

3.5 Relevant Permits

A list of permits and licenses necessary for execution of the project are indicated in the Table below.

Table 5: Required permits

TYPE OF PERMIT/APPROVAL	SUPPORTING LEGISLATION	REQUIREMENT	APPLIES TO	APPROVING AUTHORITY	TYPE OF APPLICATION SUBMITTED	STAGE AT WHICH APPROVAL IS REQUIRED
Certificate of Registration of a Workplace	The Occupational Safety and Health Act, 2006	Section 40, Subsection (2): a person shall not less than one month before he or she begins to occupy any premises as a workplace, serve on the Commissioner, a notice with the particulars prescribed in Schedule 3.	Any project requiring the establishment of a workplace (e.g., camp site).	Department of Occupational Safety and Health MGLSD	Particulars to be Submitted When Applying for the Registration of a Workplace or a Change in the Registered Occupier	Immediately upon (not later than one month) prior to undertaking any site works (construction, operation, preconstruction surveys).
Building plan approvals	Building Control Act 2013	Section 34 prohibits any person from carrying out a building operation unless he/she has a valid building permit issued by the	Applies to all commercial and residential	District Local Government	Building plans	Prior to commencement of construction

		District Building Committee	buildings			
--	--	-----------------------------	-----------	--	--	--

3.6 World Bank Environmental and Social Standards

Table 3-6: World Bank Environmental and Social standards

<p>ESS1: Assessment and Management of Environmental and Social Risks and Impact</p>	<p>ESS1 provides for carrying out an environmental and social assessment of the project to assess the environmental and social risks and impacts of the project throughout the project life cycle.</p> <p>Given that the scale of this renovation project and associated environmental and social risks are minimal, an ESMP was prepared to ensure the risks are mitigated during the implementation of the project.</p>	<p>Triggered/applicable</p>
<p>ESS2: Labor and Working Conditions</p>	<p>Recognizes the importance of employment creation and income generation in the pursuit of poverty reduction and inclusive economic growth. Borrowers can promote sound worker-management relationships and enhance the development benefits of a project by treating workers in the project fairly and providing safe and healthy working conditions</p> <p>Both skilled and unskilled labour force will be required on the project and therefore requirements of this standard to ensure appropriate working conditions shall have to be complied with.</p>	<p>Triggered/ applicable</p>
<p>ESS3: Resource Efficiency and Pollution Prevention and Management</p>	<p>Recognizes that economic activity and urbanization often generate pollution to air, water, and land, and consume finite resources that may threaten people, ecosystem services and the environment at the local, regional, and global levels. This ESS3 sets out the requirements to address resource efficiency and pollution prevention and management throughout the project life-cycle.</p> <p>ESS3 applies to the project due to the nature of the proposed</p>	<p>Triggered/ applicable</p>

	<p>activities. Therefore, measures to avoid pollution and ensure efficient resource utilization shall have to be implemented in line with this standard.</p>	
<p>ESS4: Community Health and Safety</p>	<p>ESS4 recognizes that project activities, project equipment and infrastructure increase the exposure of project stakeholder communities to various health, safety and security risks and impacts and thus recommends that projects implement measures that avoid or limit the occurrence of such risks.</p> <p>The project is expected to pose health and safety risks to the community, workers in the host environments. Therefore, provisions of these standards shall be complied with through mitigation measures that resolve these potential risks.</p>	<p>Triggered/ applicable</p>
<p>ESS5: Land Acquisition, Restrictions on Land Use and Involuntary Resettlement</p>	<p>ESS5 promotes consideration of feasible alternative project designs to avoid or minimize land acquisition or restrictions on land use, especially where this would result in physical or economic displacement, while balancing environmental, social, and financial costs and benefits, and paying particular attention to gender impacts and impacts on the poor and vulnerable. ESS5 does not apply to this project since the land where the renovation is located is owned by NFA.</p> <p>The renovation will not require land acquisition and resettlement since all the project areas are the property of the implementing agency. Therefore, this standard will not be relevant for the renovation project.</p>	<p>Not Triggered/ not applicable</p>
<p>ESS6: Biodiversity Conservation and Sustainable Management of</p>	<p>ESS6 recognizes that protecting and conserving biodiversity and sustainably managing living natural resources are fundamental to sustainable development and it recognizes the importance of maintaining core ecological functions of habitats, including forests, and the biodiversity they support.</p> <p>Some of the mitigation measures mentioned in this ESMP are</p>	<p>Triggered/ applicable</p>

<p>Living Natural Resources</p>	<p>aimed at addressing issues under ESS6.</p> <p>The renovation are to be established in sensitive ecosystems such as forests, reserves and therefore there is a need to comply with the provisions of this standard.</p>	
<p>ESS7: Indigenous Peoples/Sub- Saharan African Historically Underserved Traditional Local Communities</p>	<p>This ensures that the development process fosters full respect for the human rights, dignity, aspirations, identity, culture, and natural resource-based livelihoods of Indigenous Peoples. ESS7 is also meant to avoid adverse impacts of projects on Indigenous Peoples.</p> <p>The renovation project will not affect indigenous communities and therefore this standard will not be relevant.</p>	<p>Not Triggered/not applicable</p>
<p>ESS8: Cultural Heritage</p>	<p>This standard sets out general provisions on cultural heritage preservation and recommends protecting cultural heritage from the adverse impacts of project activities.</p> <p>The renovation locations shall not impact any cultural resources based on the assessments. However, in case there are chance finds during the execution of the projects, the chance finds protocol as in annex 3 shall be used hence triggering this standard.</p>	<p>Triggered/ applicable</p>
<p>ESS9: Financial Intermediaries (FI)</p>	<p>This recognizes that strong domestic capital and financial markets and access to finance are important for economic development, growth and poverty reduction. FIs are required to monitor and manage the environmental and social risks and impacts of their portfolio and FI subprojects and monitor portfolio risk, as appropriate to the nature of intermediated financing. How the FI will manage its portfolio will take various</p>	<p>Not Triggered/not applicable</p>

	forms, depending on some considerations, including the capacity of the FI and the nature and scope of the funding to be provided by the FI. ESS9 does not apply to this project	
ESS10: Stakeholder Engagement and Information Disclosure	ESS10. The standard establishes a systematic approach to stakeholder engagement and helps to identify stakeholders and build and maintain a constructive relationship with them, as well as disclose information on the environmental and social risks and impacts to stakeholders in a timely, understandable, accessible and appropriate manner and format. It recommends that stakeholder engagements be commenced as early as possible in the project development process and continued throughout the lifecycle of the Project. For this renovation project, relevant stakeholders were engaged in line with the provisions of this standard and other requirements of this standard will be complied with.	Triggered/ applicable

3.7 List of Plans to be Included in The Contractor’s C-ESMP

The following plans shall constitute the Contractor’s Social and Environmental Management Plan.

S/N	Plan
1.	Waste Management Plan
2.	Occupational and Community Health and Safety Management Plan
3.	Emergency Response Procedures
4.	Decommissioning and Restoration Plan

4 METHODOLOGY

The methodology section highlights the methods that were used in the development of this ESMP.

4.1 Environmental and Social Screening

Environmental and social screening are important processes used to identify, assess, and manage the potential environmental and social risks and impacts associated with activities.

The sub-project was subjected to the project screening checklist and it was determined that the potential adverse risks and impacts on human populations and/or the environment are not likely to be significant. The likely impacts are mostly predictable and expected to be low in magnitude, temporary and/or reversible, site-specific, without likelihood of impacts beyond the actual project. It was after the environmental screening that it was determined that an ESMP would be adequate to mitigate the likely environmental and social impacts and risks.

4.2 Document Review

To gain a clear insight on baseline parameters and project characterization, various planning, regulatory documents and reports were analyzed. Reviewed documents include those on policy and regulatory provisions

1. World Bank Environmental and Social Framework
2. National Legal and Regulatory Framework

4.3 Site Reconnaissance

The proposed sub-project area was examined during the site visit. The observation and assessment of the physical characteristics of the proposed site, the immediate surrounding and other environmental and social attributes likely to affect or be affected by the implementation of the sub-project was undertaken. The site characteristics are detailed in section 2.24 of this ESMP.

The site visit assisted in identifying and assessing the likely impacts as a result of the project implementation. The site visits also assisted in establishing baselines (i.e., biological and physical) to be used in monitoring compliance of the project to the proposed mitigation measures.

4.4 Stakeholder Consultations

Stakeholder consultations allow those most affected by proposed developments to make an input at both planning and operation stages.

The aim of the consultations was to identify and take note of environment and social concerns and views of stakeholders so that appropriate mitigations are incorporated.

Consultations were carried out with key NFA staff at Budongo Central Forest Reserve, community leaders, community members and the District officials to obtain their comments on the proposed project with respect to the potential environmental and socio-economic issues and impacts.

Table 4-1: Stakeholders Consulted on the Project

Category	Stakeholders consulted
Central Forest Reserve	Forest Supervisor Forest Manager
Community	Local leaders Community Members
NFA Headquarter	IFPA-CD Institutional Focal Person IFPA-CD Project Officer IFPA-CD Procurement Officer Ecotourism officer Environment Management and Research Officer Administration Officer Planning Officer
District	Environment Officer District Community Development Officer

	District Forest Officer
National	Ministry of Tourism Wildlife and Antiquities Ministry of Water and Environment Uganda Wildlife Authority (UWA) Ministry of Gender, Labour and Social Development.

For each engagement, the consultant disclosed information along the thematic areas here below;

1. Introduction of project team.
2. Purpose of the meeting
3. Project Description and Planned Activities
4. Project Partners and their roles;
5. Perceived project impacts (positive and negative) and proposed mitigation

4.1.1 Engagement Activities

Stakeholder consultations were undertaken in April 2024 to disclose the proposed project to the NFA field staff, to seek their views about its development and operation. The nearest Community were consulted since they were within the site vicinity. In addition, district representatives were engaged to seek their opinions on the proposed projects.

During the stakeholder engagements, the stakeholders raised concerns/issues. Some of the key concerns raised during the various stakeholder engagement meetings are summarized in the table below.

Table 4-2: Summary of Key Issues Raised by Stakeholders

Stakeholder	Key Issues Raised	Consultants' response
<p>Community leaders</p>	<ul style="list-style-type: none"> • Provision of employment Opportunities • Improve on the Road • Improve on Security in the area 	<ul style="list-style-type: none"> • The consulting team assured the community leaders that various opportunities will be created to be occupied by the community members. • The consulting team recommended enhancing security measures through NFA patrol team, and collaboration with local law enforcement agencies.
<p>National Forest Authority (NFA) field Team</p>	<ul style="list-style-type: none"> • Provide Safety Kits. • Provision of Power. • Provision of Uniforms for identity. • Provision of water at the housing facilities. 	<ul style="list-style-type: none"> • Safety kits will be provided, ensuring everyone has the necessary protective equipment. • A reliable power sources, (solar panels) will be installed, to ensure a continuous power supply. • Uniforms will be provided to improve team identity and professionalism
<p>District team</p> <ul style="list-style-type: none"> • District Environmental Officer (DEO) • District Community Development Officer. 	<ul style="list-style-type: none"> • Ensure that ownership of land is identified • Ensuring the project complies with local, national, and international environmental laws and regulations is crucial. • Employment opportunities. • Providing training and capacity-building programs for 	<ul style="list-style-type: none"> • The site is within the NFA protected area and NFA owns the land. • The consulting team assured us of adhering to all relevant environmental laws and regulations. • The consulting team assured to create job opportunities for local residents throughout

<ul style="list-style-type: none"> • District Forestry Officer 	<p>local residents to enable them to benefit from the project.</p> <ul style="list-style-type: none"> • Ensure HIV/AIDS awareness in the management Plans. • Implementing measures to protect critical habitats and prevent illegal logging or encroachment. • Ensuring that biodiversity conservation plans are integrated into the project's planning. • Ensuring the project complies with all relevant forestry laws, regulations, and policies 	<p>the project.</p> <ul style="list-style-type: none"> • Training programs to enhance local residents' skills and capacity to benefit from the project will be provided. • HIV/AIDS awareness programs in the project's management plans has provided. • Proposed measures to protect critical habitats and prevent illegal activities have been developed. • The consulting team committed to integrating biodiversity conservation plans into the project's planning stages. • Consultants reassured compliance with all forestry laws, regulations, and policies.
<p>Community Members</p>	<ul style="list-style-type: none"> • There could be potential benefits in terms of improved infrastructure, such as roads • Construction could lead to restrictions on access to forest resources that community members rely on for subsistence and income. • Job Opportunities 	<ul style="list-style-type: none"> • Proposed alternative solutions and compensatory measures to mitigate restrictions on access to forest resources was disc. • The consulting team assured the community members that various opportunities will be created for them.
<p>Uganda Wildlife Authority (UWA)</p>	<ul style="list-style-type: none"> • Avoid Pollution and Disturbance • Ensuring that the project complies with local, national, and international wildlife 	<ul style="list-style-type: none"> • The consulting team assured UWA that measures would be taken to minimize pollution and disturbance during the project, including careful planning and implementation of best practices.

	<p>protection laws and environmental regulations.</p>	<ul style="list-style-type: none"> The project would adhere to all relevant wildlife protection laws and environmental regulations.
<p>National Forest Authority (NFA) Top management</p>	<ul style="list-style-type: none"> The Consultant presented a draft report highlighting; the field findings, design concept, renovations, budget estimates, environmental assessment and revised schedule. The Consultant noted that there was a discrepancy in the proposed infrastructure developments in the ToRs and the field findings. According to the Tor’s a total of 52 buildings had been proposed while the field findings had a total of 104 sites. He requested the client to guide on the scope to be covered. 	
<p>Ministry of Water and Environment (W&E)</p>	<ul style="list-style-type: none"> The Code of conduct for workers should be laid out Occupational health and safety needs to be emphasized on the sites such as sexual Orientation should be carried out to the workers. There needs to be no land encumbrances on the sites 	<ul style="list-style-type: none"> The consulting team agreed to implement a strict code of conduct for workers, emphasizing occupational health and safety, including training on issues such as sexual orientation sensitivity. Consulting team acknowledged the importance of clear land ownership and assurance the ministry that the project site is within the protected area and it’s owned

	<p>where the facilities are to be set up (the site is within the gazetted CFR).</p>	<p>by NFA so there won't be any land encumbrances.</p>
--	---	--

5 ANTICIPATED IMPACTS AND MITIGATION MEASURES

This chapter lays out a discussion of the most pertinent environmental and social impacts of the proposed renovation project. In addition, the possible mitigation measures to manage the impacts are also proposed.

5.1 Positive impacts

5.1.1 Improved Living Conditions for Staff

The establishment and improvement of the accommodation facilities will enhance comfort, safety, and health of the staff. Upgraded housing with modern amenities and better sanitation reduces safety hazards and health risks, leading to increased staff well-being and satisfaction. This, in turn, boosts productivity and job performance, supports a better work-life balance, and aids in retaining and attracting skilled employees.

5.1.2 Increased Productivity and Morale

Improving staff housing within Budongo CFR enhances productivity and morale by creating a comfortable and supportive living environment. Upgraded housing leads to higher employee satisfaction and engagement, which translates into better performance and efficiency on the job. Reduced turnover and associated training costs result in increased staff retention, while boosted morale fosters a more motivated and cohesive team.

5.1.3 Increased Health Benefits

The project will offer significant health benefits by enhancing hygiene, sanitation, and overall living conditions. Modernized housing with better sanitation facilities and clean water reduces the risk of waterborne diseases, while improved air quality and ventilation contribute to respiratory health. Comfortable and secure living environments also reduce stress, supporting better mental well-being. Additionally, addressing safety hazards minimizes the risk of injuries and accidents, and well-designed living spaces can encourage healthier lifestyles.

5.1.4 Employment Opportunities

Renovation will require both skilled and unskilled labour for the project to be well executed. This shall provide opportunity for employment of locals around the Reserve especially in regard to manual labour, and hence improving their standards of living.

5.1.5 Market for Construction Materials

Construction materials such as bricks, sand, aggregates, and cement shall be required during the renovation. These will be acquired from the neighbouring trading centres and hence increasing income for the business operators around the Reserve.

5.2 Negative Impacts

5.2.1 Construction Phase Impacts

5.2.1.1 Vegetation Loss

Clearing vegetation is essential to create space for construction activities and ensure smooth access for equipment, vehicles, and workers involved in the renovation process. Additionally, the movement of workers and machinery, as well as other operational activities, can unintentionally damage surrounding vegetation. In these cases, limited clearing of vegetation around the site helps facilitate the renovation works while ensuring safe and efficient operations. The vegetation around the renovation sites are not ecologically sensitive, and the scale of the renovations is often too small to have a

major ecological impact. Nonetheless, careful planning is necessary to minimize disruption and implement mitigation measures where possible.

Mitigation measures

- Vegetation clearance will be limited strictly to the project area, ensuring that the extent of clearing is minimized.
- Trees that may serve as habitats for species will be selectively removed to limit habitat disturbance.
- A targeted approach to vegetation clearing will be applied, prioritizing thorough surveys to protect areas of high biodiversity and avoid the removal of rare or ecologically valuable plant species.
- Re-vegetation efforts will be undertaken after the renovation is completed, to compensate for the temporary loss of vegetation.
- Workers and staff will be trained on minimizing damage to vegetation, with resting areas provided to reduce unnecessary trampling and destruction.

5.2.1.2 Soil and Geological Disturbances

In the renovation of existing office buildings and staff accommodations, there will be minimal soil and geological disturbances as no excavation will be required. However, minor disturbances could still occur due to the movement of heavy equipment, foot traffic, and other activities related to the renovation process. These disturbances may slightly affect the topsoil and the habitat of surface-dwelling organisms in the project area.

Mitigation Measures

- Limit movement and activities to designated areas to prevent unnecessary soil compaction or surface disturbance.
- Implement protective measures, such as ground covers or temporary pathways, to minimize the impact of foot traffic and equipment on the soil.

- Ensure that any minor soil disturbance is restored through re-vegetation or other methods to maintain soil stability after the renovation is completed.

5.2.1.3 Wildlife Disturbance

Construction activities such as haulage of construction materials, breaking, and the existence of more people in the Reserve are likely to cause disturbances to the wildlife. This can cause retaliation if provoked hence causing dangers to the workers and in some cases causing migration of species away from the construction area.

Mitigation Measures

- Sensitisation of workers on the dos and don'ts while working in Budongo Central Forest Reserve shall be carried out by NFA field teams before and during the renovation works.
- The NFA field team shall move with the construction team at all times to ensure that the renovation activities cause minimal disturbances to the wildlife.
- Working hours shall be restricted to daytime and this will ensure less disturbance to the wildlife.

5.2.1.4 Deforestation

The project activities will increase access to the forest by the contractor's workers. This can be used by the illegal loggers as a chance of entry into the forest reserve and engage in deforestation activities. In addition, workers may cut trees for use as firewood, and furniture which is illegal.

Mitigation Measures

- Sensitisation of construction workers on illegal activities in the forest Reserve shall be done.
- NFA Field staff shall be assigned to supervise the movements of the Contractors workers while in the forest reserve and hence minimise risks of tree cutting.

- All workers shall be offered identification tags for recognition as they enter and carry out the construction activities in the forest reserve since they are near the communities.
- Contractors shall be monitored and encouraged to avoid redundant labourers at the site.

5.2.1.5 Noise

Noise is expected to come from construction activities such as generators running the welding equipment as well as human interactions. Noise can attract animals which can be dangerous to the workers. In the same manner, noise can cause interference in the communication of some animals and bird species. These can be forced to leave their habitat and look for alternative favourable places.

Mitigation Measures

- Noise generating activities shall be restricted to daytime only.
- Personal Protective Equipment such as earbuds shall be provided to workers to minimize impact of noise to their health.
- Sound harnessers such as mufflers shall be used in generators and drilling equipment to minimize the noise generated.
- Scheduling of delivery of material in specific times shall be done to minimize impact of noise due to vehicular movements.
- Maintenance and regular servicing of equipment shall be carried out to ensure they are in good operating condition.

5.2.1.6 Poor Waste Management

Poor management of domestic waste, hazardous waste and human excreta can affect the aesthetics of areas by making them untidy. Improper handling of hazardous waste and human excreta can lead to contamination of land and water resources. Waste should therefore be managed in accordance with the national waste management regulations of 2020.

Mitigation Measures

- Regular sensitisation of workers on proper waste management practices shall be done.
- Coded (and labelled) waste bins shall be provided and placed around at each site for waste collection and ensure waste segregation.
- All waste collected shall be disposed of outside the protected area in an environmentally sound manner.
- Contractors shall be encouraged to prepare and implement a detailed site-specific waste management plan for the renovation.
- Mobile toilets shall be provided to ensure that sanitation is observed at the construction site and hence prevent diseases related to poor sanitation.

5.2.1.7 Air and Dust Emission

Drilling activities, vehicle traffic, concrete mixing at the site are expected to generate dust. In addition, traffic and other equipment using fossil fuels that release hydrocarbons and other gases including carbon dioxide, nitrous oxides, sulphur oxides, and particulate matter will also pollute the air at the site. These can cause eye irritations and respiratory tract diseases among others.

Mitigation Measures

- PPE shall be provided to all workers at the construction site to minimise air pollution impacts on their health.
- Vehicles shall be limited to the speed as per the reserve to minimise dust raising on the murrum roads.
- Haulage trucks will be covered with tarpaulin while transporting construction and spoil material to and from the sites.
- Regular maintenance of vehicles shall be carried out to minimise the emission of hydrocarbons.

5.2.1.8 Occupational Health and Safety Risks to Workers

Construction sites come with different risks while executing the activities. While undertaking the renovation works, accidents, injuries, cuts, falls from heights, disease outbreak due poor sanitary conditions, among others are some of the anticipated risks at the site. These can cause pain, at times death to the workers and hence the need to manage these impacts and avoid their occurrences during project implementation.

Mitigation Measures

- Sensitisation of workers on likely risks at the site shall be carried out routinely including daily toolbox talks before any activities start.
- PPE that are specific to each worker’s roles shall be issued out to ensure minimum risks to human health during renovation works. First Aid kits shall be provided at each site to offer aid to injured workers.
- A trained first aider shall be available at each site to ensure that all first aid cases are adequately handled while at the site.
- Emergency response procedures shall be prepared, displayed and workers trained on such so as to be ready in case of any emergency.
- Warning signage shall be provided on site and along the traffic routed to remind all workers, staff and site visitors on the health and safety aspects in the project area.
- A MoU with a nearby health facility shall be set up to ensure medical cases are handled at the facility in cases where first aid is not sufficient.

5.2.1.2 Staff Safety Risks Associated with Renovation Activities

- Exposure to Construction Hazards: Staff may face risks such as falling debris, dust, and injuries from tools and machinery during renovation.
- Compromised Structural Stability: Partial demolitions could temporarily weaken building structures, posing risks to occupants.
- Health Hazards from Dust and Emissions: Dust and fumes from paints or adhesives may cause respiratory or health issues.

- Limited Access to Amenities: Renovations may disrupt access to kitchens, bathrooms, and water supply.
- Noise Pollution: High noise levels may affect mental well-being and daily activities.
- Electrical and Fire Risks: Rewiring or electrical works may increase risks of fire or electrocution.

Mitigation Measures

- Temporary Relocation of Staff: Staff will be relocated to alternative accommodations during the renovation.
- Segregated Work Zones: Clear barriers will be installed to separate construction and occupied areas.
- Personal Protective Equipment (PPE): PPE such as helmets and masks will be provided to staff as necessary.
- Dust and Fume Management: Dust suppression measures and exhaust systems will manage air quality.
- Schedule Work Strategically: Hazardous activities will be scheduled during non-working hours.
- Structural Assessments: Structural evaluations will ensure phased renovations without compromising safety.
- Emergency Preparedness: Fire safety measures and first aid kits will be in place, with staff trained in evacuation procedures.
- Communication and Notifications: Staff will be informed about schedules, disruptions, and safety measures.

5.2.1.9 Sexual Harassment and Risks of HIV

Construction of the renovation can involve sexual harassment at the site and off the site, to fellow workers. This can cause uncomfortable working conditions which can lead to poor performance while at work. In addition, HIV/AIDS can easily spread around construction sites where sexual relations are likely to occur among workers of different sex or back in the community where the workers stay after work.

Mitigation Measures

- Sensitisation of workers on sexual harassment and HIV shall be carried out prior to deployment to the site and continuous engagements shall also be carried out to remind the workers.
- Condoms shall be provided to workers for usage in case they cannot abstain from sex while still on the project.
- Access to primary health care such as availability of ARVs for HIV positive workers shall be prioritized to ensure work does not affect their health needs.

5.2.2 Operation phase

5.2.2.1 Poor Waste management

During operation of the renovation, waste is expected to be generated by the Field staff teams who will be using the renovation as required. Since no food is allowed within the Reserve, the main waste streams expected will include plastic material such as water bottles and human waste. Plastic wastes degrade the aesthetics of the Reserve hence making the Reserve unappealing, while poor human waste management can cause diseases due to poor sanitation practices such as cholera.

Mitigation Measures

- Sensitisation of Field staff teams on proper waste management practices shall be done to ensure proper implementation of waste management strategies during the operational phase.
- Coded waste bins shall be provided and placed around the renovation to ensure waste segregation and onsite collection.
- All waste collected shall be disposed of outside the protected area in an environmentally sound manner.
- Sanitary facilities should be routinely cleaned to minimise risks of diseases.

5.2.2.2 Occupational Health and Safety risks and impacts

During operation of the office and staff accommodation facilities, there are risks involved such as falls from the staircases/ platforms, attacks by wild animals, among others. The probability of occurrence of these impacts is low since the field staff that will be occupying the renovated facilities are well trained individuals.

Mitigation Measures

- Field staff teams will be sensitized on the health and safety risks that are associated with operation of the renovation, so as to minimise the occurrence.
- First Aid kits shall be provided at the field staff teams' residences for easy access in case of any injuries at the workplace.
- Emergency response procedures for the operation of the renovation shall be set up to ensure effective operation and management of the facilities.

5.2.2.3 Visual impacts

The establishment of the renovation affects the visual aesthetics of the wildlife reserve and may be an obstruction to flying vessels which may knock it and hence causing accidents in the Reserve.

Mitigation Measures

- The renovation shall be painted with green colour that blends into the natural setting of the Reserve and hence reducing on the visual impacts.

6 ENVIRONMENTAL AND SOCIAL MANAGEMENT AND MONITORING PLAN

The purpose of environmental and social monitoring is to evaluate the effectiveness of the implementation of the Environmental and Social Management Plan (ESMP) by periodically monitoring the important environmental parameters within the impact area so that any adverse effects are detected and timely action can be taken.

The environmental management and monitoring plan has been developed to ensure the implementation of the mitigation measures identified. The monitoring will begin during the construction and must continue throughout all the phases of the project.

The ESMPs outlined in tables hereafter address the potential negative impacts and mitigation measures as well as roles, and monitorable indicators that can help to determine the effectiveness of actions to upgrade the quality of environment; as regards the proposed project.

6.1 Monitoring team

The implementation of the project shall be monitored by NFA staff both at HQ and field level. Below are the specific roles for the team personnel.

6.1.1 EIA Unit

- NFA incorporate ESMP into the detailed technical designs and civil works bidding and contractual documents;
- Providing relevant inputs to the contractor selection process and the procurement process.
- Reviewing reports submitted by the contractor on the implementation of the mitigation measures proposed;
- Conducting periodic site checks to assess compliance with the proposals made in this ESMP.

6.1.2 Project Coordination Unit (PCU).

- Project coordination involves developing project plans, defining objectives, setting timelines, and allocating resources effectively.

- The PCU oversees budget allocation and financial management for the project, ensuring that funds are used efficiently and in accordance with project goals and guidelines.
- It is responsible for preparation of regular reports for project funders, government agencies, and other stakeholders to demonstrate project progress and compliance.
- The PCU monitors the progress of the project including the environmental and social performance, collects data on key performance indicators, and evaluates the project's effectiveness.

6.2 Grievance Management

The National Forestry Authority (NFA) has established a comprehensive Grievance Redress Mechanism (GRM) to effectively manage and address community grievances arising from the projects it implements. This system ensures that concerns from community members are promptly resolved at the local level. The mechanism enables the use of the existing local-level Grievance Redress Committees (GRCs) within project areas to address any complaints or issues that may arise during project execution.

To further enhance this process, NFA has set up a toll-free line (0800 264036) and (WhatsApp 0707608920) that community members can use to report their grievances directly and receive timely assistance. This is in addition to the physical GRCs, offering a more accessible platform for all stakeholders.

In line with the Environmental and Social Standards (ESS2) of the World Bank's Environment and Social Standards, all contractors working on NFA projects are mandated to establish a grievance mechanism for direct and contracted workers. This system ensures that workplace-related concerns are addressed in a fair and timely manner. Contractors are required to implement this grievance mechanism immediately after contract signing and prior to site mobilization. Workers will be represented on the GRC, which will be fully functional once workers are on-site, allowing their concerns to be integrated into the overall grievance management process.

Table 6-1: Environmental Social Management and Monitoring Plan

Environmental/ social impact	Proposed mitigation and Enhancement measures	Monitoring Indicators	Implementing Agency	Recommended Frequency of Monitoring	Monitoring Agency	Cost Estimates (Ugx)
Construction Phase						
Biological Environment						
Vegetation Loss	<ul style="list-style-type: none"> Vegetation clearance will be limited strictly to the project area, ensuring that the extent of clearing is minimized. Trees that may serve as habitats for species will be selectively removed to limit habitat disturbance. A targeted approach to vegetation clearing will be applied, prioritizing thorough surveys to protect areas of high biodiversity and avoid the removal of rare or ecologically valuable plant species. 	Area cleared Restoration Plan	Contractor	Throughout the construction phase	NFA Ecological Monitoring team, Supervising consultant	3,000,000

Environmental/ social impact	Proposed mitigation and Enhancement measures	Monitoring Indicators	Implementing Agency	Recommended Frequency of Monitoring	Monitoring Agency	Cost Estimates (Ugx)
	<ul style="list-style-type: none"> Re-vegetation efforts will be undertaken after the renovation is completed, to compensate for the temporary loss of vegetation. <p>Workers and staff will be trained on minimizing damage to vegetation, with resting areas provided to reduce unnecessary trampling and destruction</p>					
Soil and Geological Disturbances	<ul style="list-style-type: none"> Limit movement and activities to designated areas to prevent unnecessary soil compaction or surface disturbance. Implement protective measures, such as ground covers or temporary pathways, to minimize the impact of foot traffic and equipment on the soil. Ensure that any minor soil disturbance 		NFA Contractor	During the execution	NFA Ecological Monitoring team, Supervising consultant	3,000,000

Environmental/ social impact	Proposed mitigation and Enhancement measures	Monitoring Indicators	Implementing Agency	Recommended Frequency of Monitoring	Monitoring Agency	Cost Estimates (Ugx)
	is restored through re-vegetation or other methods to maintain soil stability after the renovation is completed.					
Wildlife Disturbance	<ul style="list-style-type: none"> Sensitisation of workers on the dos and don'ts while working in Budongo Central Forest Reserve shall be carried out by NFA Field staff teams before and during the construction of renovation. NFA Field staff teams shall be required to move with construction team at all times to ensure construction activities cause minimal disturbances to the wildlife. Working hours shall be restricted to day time work and this will ensure less disturbance to the Reserve wildlife 	Record of sensitization. Presence of NFA Field staff teams on site	NFA Contractor	Throughout the construction phase	NFA Ecological Monitoring team,	2,000,000
Poaching	<ul style="list-style-type: none"> Sensitisation of construction workers on 	Identification for	NFA	Throughout the	NFA	5,000,000

Environmental/ social impact	Proposed mitigation and Enhancement measures	Monitoring Indicators	Implementing Agency	Recommended Frequency of Monitoring	Monitoring Agency	Cost Estimates (Ugx)
	<p>illegal activities in the Reserve shall be done to ensure no poaching is done while the renovation is being set up.</p> <ul style="list-style-type: none"> NFA Field staff teams shall be assigned to the contractor’s team to supervise their movements while in the Reserve and hence minimise risks of poaching. All workers shall be offered with identification tags for recognition as they enter and carryout the construction activities in the Reserve. Contractors shall be monitored and encouraged to avoid redundant labourers at the site 	<p>workers NFA Field staff teams presence</p>	Contractor	construction phase	Ecological Monitoring team,	
Physical Environment						
Noise	<ul style="list-style-type: none"> Noise generating activities shall be restricted to day time only. 	Daily noise monitoring in	Contractor	Daily	NFA	8,000,000

Environmental/ social impact	Proposed mitigation and Enhancement measures	Monitoring Indicators	Implementing Agency	Recommended Frequency of Monitoring	Monitoring Agency	Cost Estimates (Ugx)
	<ul style="list-style-type: none"> • Personal Protective Equipment such as earbuds shall be provided to workers to minimise impact of noise to their health. • Sound harnessers such as muffler shall be used in generators and drilling equipment to minimise the noise generated. • Scheduling of delivery of material in specific times shall be done so as to minimise impact of noise due to vehicular movements. • Maintenance and servicing of equipment shall be carried out to ensure they are in good operating conditions. 	<p>place</p> <p>Workers with earmuffs</p>				
Poor Waste Management	<ul style="list-style-type: none"> • Sensitization of workers on proper waste management practices shall be 	Waste bins in place.	Contractor	Throughout the construction	NFA	15,000,000

Environmental/ social impact	Proposed mitigation and Enhancement measures	Monitoring Indicators	Implementing Agency	Recommended Frequency of Monitoring	Monitoring Agency	Cost Estimates (Ugx)
	<p>done to ensure proper implementation of waste management strategies.</p> <ul style="list-style-type: none"> • Coded waste bins shall be provided and placed around the construction site to ensure waste segregation and onsite collection. • All waste collected shall be disposed of outside the protected area in an environmentally sound manner. • Contractors shall be encouraged to prepare and implement a detailed site-specific waste management plan for the renovation. • Mobile toilets shall be provided to ensure that sanitation is observed at the construction site and hence prevent diseases related to poor sanitation. 	<p>Record of wastes taken off site.</p> <p>Contractor's Waste Management Plan</p>		<p>phase</p>		

Environmental/ social impact	Proposed mitigation and Enhancement measures	Monitoring Indicators	Implementing Agency	Recommended Frequency of Monitoring	Monitoring Agency	Cost Estimates (Ugx)
Air and dust emissions	<ul style="list-style-type: none"> PPEs shall be provided to all workers at the construction site to minimise air pollution impacts on their health. Vehicles shall be limited to a prescribed speed to minimise dust raising on the murrum roads. Haulage trucks will be covered with tarpaulins to ensure dust is not released as vehicles are transporting both construction and spoils material to and from the site. Regular maintenance of vehicles shall be carried out to minimise the emission of hydrocarbons from their exhaust. 	<p>Air quality monitoring measures in place.</p> <p>Workers with PPEs such as masks.</p>	Contractor	Daily, weekly & quarterly monitoring	NFA,	6,000,000
Socio-Economic Environment						
Occupational health & safety	<ul style="list-style-type: none"> Sensitisation of workers on likely risks at the site shall be carried out routinely 	First Aid Kit available at the	Contractor	Random inspections	NFA,	10,000,000

Environmental/ social impact	Proposed mitigation and Enhancement measures	Monitoring Indicators	Implementing Agency	Recommended Frequency of Monitoring	Monitoring Agency	Cost Estimates (Ugx)
risks for workers	<p>including toolbox talks at commencement of new tasks.</p> <ul style="list-style-type: none"> • PPEs that are specific to each worker’s roles shall be issued out to ensure minimum risks to human health during operation of the site. • First Aid kit shall be provided at the site to offer aid to injured workers. • A trained first aider shall be available at the site to ensure that all first aid cases are adequately handled while at the site. • Emergency response procedures shall be prepared, displayed and workers trained on such so as to be ready in case of any emergency. • Warning signage shall be provided on 	<p>site</p> <p>Safety awareness programs</p> <p>Workers dressed up in full PPEs</p>				

Environmental/ social impact	Proposed mitigation and Enhancement measures	Monitoring Indicators	Implementing Agency	Recommended Frequency of Monitoring	Monitoring Agency	Cost Estimates (Ugx)
	<p>site and along the traffic routed to remind all workers, staff and site visitors on the health and safety aspects in the project area.</p> <ul style="list-style-type: none"> An MoU with a nearby health facility shall be set up to ensure medical cases are handled at the facility in cases where first aid is not sufficient. 					
Sexual Harassment and Risks of HIV	<ul style="list-style-type: none"> Sensitisation of workers on sexual harassment and HIV shall be carried out prior to deployment to the site and continuous engagements shall also be carried out to remind the workers. Condoms shall be provided to workers for usage in case they cannot abstain from sex while still on the project. Access to primary health care such as 	<p>Record of sensitization on Sexual harassment.</p> <p>Condom dispensers</p>	Contractor	Weekly	NFA	

Environmental/ social impact	Proposed mitigation and Enhancement measures	Monitoring Indicators	Implementing Agency	Recommended Frequency of Monitoring	Monitoring Agency	Cost Estimates (Ugx)
	availability of ARVs for HIV positive workers shall be prioritized to ensure work does not affect their health needs.					
Operational Phase						
Physical Environment						
Poor waste management	<ul style="list-style-type: none"> Sensitization of Field staff teams on proper waste management practices shall be done to ensure proper implementation of waste management strategies during the operational phase. Coded waste bins shall be provided and placed around the renovation to ensure waste segregation and onsite collection. All waste collected shall be disposed of outside the protected area in an environmentally sound manner. 	Waste Bins in place. Status of sanitary facilities	NFA Field staff teams	Random inspections	NFA HQ team	3,000,000

Environmental/ social impact	Proposed mitigation and Enhancement measures	Monitoring Indicators	Implementing Agency	Recommended Frequency of Monitoring	Monitoring Agency	Cost Estimates (Ugx)
	<ul style="list-style-type: none"> Sanitary facilities should be routinely cleaned to minimise risks of diseases. 					
Socio-economic Environment						
Occupational Health and Safety	<ul style="list-style-type: none"> Field staff teams will be sensitized on the health and safety risks that are associated with the operation of the renovation, to minimise the occurrence. A First Aid kit shall be provided at the Field staff teams' house to ensure easy access services to first aid in case of any injuries at the workplace. Emergency response procedures for the operation of the renovation shall be set up to ensure effective operation and management of the project. 	First Aid kit on site. Emergency response procedures displayed	NFA	Daily	NFA HQ team.	5,000,000
Visual Impacts	<ul style="list-style-type: none"> The renovation shall be painted with a green colour that blends into the natural 	Colour of the renovation	NFA HQ team	Bi-annually	NFA field team,	3,000,000

Environmental/ social impact	Proposed mitigation and Enhancement measures	Monitoring Indicators	Implementing Agency	Recommended Frequency of Monitoring	Monitoring Agency	Cost Estimates (Ugx)
	setting of the Reserve hence reducing on the visual impacts.				HQ team	
Maintenance and Decommissioning Impacts	<ul style="list-style-type: none"> • Ensure that maintenance crews have appropriate safety wear and tools for all maintenance activities. • Decommissioning activities such as disassembly of the tower should be carried out by competent professionals to minimise cases of accidents due to incompetence. • Maintenance and decommissioning activities should be carried out during the day time only. 	<p>Safety checklists filled by the maintenance crew.</p> <p>Competence certificate for contractor to decommission project</p>	NFA Contractors	<p>Quarterly Maintenance</p> <p>At the end of the project</p>	NFA field team, HQ team	8,000,000

7 CONCLUSION

From the assessment undertaken during this study, it can be concluded that the implementation of this project will have low risk environmental and social impacts. Mitigation measures have been identified to address the anticipated impacts.

Therefore, it's imperative to ensure that the mitigation measures suggested are implemented during the execution of the project.

REFERENCES

Howard, P. C. and Davenport, T. R. B. (1996) Forest biodiversity reports. Volumes 1–33.

Kampala: Uganda Forest Department.

The constitution of the Republic of Uganda 1995, Kampala-Uganda

The Employment Act, 2006, Kampala Uganda

The Land Act, Cap 227, Kampala Uganda

The National Environment (Waste Management) Regulations, No.49 of 2020

The National Environment Act, No.5 of 2019

The National Environment Management policy, 1994, Ministry of Natural Resources, Kampala-Uganda.

Bennun, L., Davies, G., & Howell, K. (2002). African Forest Biodiversity A Field Survey Manual for Vertebrates. In *Earthwatch*.

APPENDICES

APPENDIX 1: CODES OF CONDUCT

A. Company's Code of Conduct

The Contractor is expected to be committed to ensuring that the project is implemented to minimize any negative impacts on the local environment, communities, and its workers. This will be done by respecting the Environmental, Social, Health and Safety (ESHS) standards, and ensuring appropriate Occupational Health and Safety (OHS) standards are met. The Contractor should also be committed to creating and maintaining an environment where children under the age of 18 will be protected, and where Sexual Exploitation and Abuse (SEA) and sexual harassment have no place. Improper actions towards children, SEA and sexual harassment are acts of Gender Based Violence (GBV) and Violence against Children and as such will not be tolerated by any employee, supplier, associate, or representative of the Contractor.

Therefore, to ensure that all those engaged in the project are aware of this commitment, the Contractor will be required to commit to the following core principles and minimum standards of behavior that will apply to all Contractor employees, associates, and representatives, including Managers and suppliers, without exception:

General

- The Contractor – and therefore all employees, associates, representatives, Managers and suppliers – shall commit to complying with all relevant national laws, rules and regulations.
- The Contractor shall commit to fully implementing the Environmental and Social Management Plan ESMP as approved by the Project.
- The Contractor shall commit to treating women, children (persons under the age of 18), and men with respect regardless of race, colour, language, religion, political or other opinion, national, ethnic or social origin, property, disability, birth or other status. Acts of GBV and VAC are in violation of this commitment.

- The Contractor shall ensure that interactions with local community members are done with respect and non-discrimination.
- Demeaning, threatening, harassing, abusive, culturally inappropriate, or sexually provocative language and behavior are prohibited among all Contractor employees, associates, and its representatives, including sub-Managers and suppliers.
- The Contractor will follow all reasonable work instructions (including regarding environmental and social norms).
- The Contractor will protect and ensure proper use of property (for example, to prohibit theft, carelessness or waste).

❖ Health and Safety

- The Contractor will ensure that the project’s OHS Measures are effectively implemented by Contractor’s staff, as well as Managers and suppliers.
- The Contractor will ensure that all persons on-site wear prescribed and appropriate personal protective equipment, preventing avoidable accidents, and reporting conditions or practices that pose a safety hazard or threaten the environment.

The Contractor will:

- Prohibit the use of alcohol during work activities.
- Prohibit the use of narcotics or other substances which can impair faculties at all times.
- The Contractor will ensure that adequate sanitation facilities are available on site
- The Contractor will not hire children under the age of 18 for construction work, or allow them on the work site, due to the hazardous nature of construction sites.

Gender Based Violence and Violence Against Children

- Acts of GBV and VAC constitute gross misconduct and are therefore grounds for sanctions, which may include penalties and/or termination of employment and, if appropriate, referral to the Police for further action.
- All forms of GBV and VAC, are unacceptable, regardless of whether they take place on the work site, the work site surroundings, or within the local community.

- Sexual harassment of work personnel and staff (e.g. making unwelcome sexual advances, requests for sexual favours, and other verbal or physical conduct of a sexual nature) are acts of GBV and are prohibited.
- Sexual favors (e.g. making promises of favorable treatment such as promotions, threats of unfavorable treatment such as losing a job, payments in kind or in cash dependent on sexual acts) and any form of humiliating, degrading or exploitative behavior are prohibited.
- The use of prostitution in any form at any time is strictly prohibited.
- Sexual contact or activity with children under 18—including through digital media—is prohibited. Mistaken belief regarding the age of a child is not a defence. Consent from the child is also not a defence or excuse.
- Unless there is full consent by all parties involved in the sexual act, sexual interactions between the Contractor’s employees (at any level) and members of the communities surrounding the work place are prohibited. This includes relationships involving the withholding/promise of actual provision of benefit (monetary or non-monetary) to community members in exchange for sex (including prostitution). Such sexual activity is considered “non-consensual” within the scope of this Code.
- In addition to Contractor sanctions, legal prosecution of those who commit acts of GBV and VAC will be pursued if appropriate.
- All employees, including volunteers and sub-contractors are highly encouraged to report suspected or actual acts of GBV and VAC by a fellow worker.

Implementation

To ensure that the above principles are implemented effectively, the Contractor commits to:

- ✚ Ensuring that all employees sign the ‘Individual Code of Conduct’ confirming their agreement to comply with ESHS and OHS standards, and not to engage in activities resulting in GBV and VAC, child endangerment or abuse, or sexual harassment.
- ✚ Displaying the Contractor and Individual Codes of Conduct prominently and in clear view, in offices, and in in public areas of the work space.

- ✚ Ensuring that all employees attend an induction training course prior to commencing work on site to ensure they are familiar with the Contractor’s commitments to ESHS and OHS standards, and the project’s GBV and VAC Codes of Conduct.
- ✚ Ensuring that all employees attend a mandatory training course once a month for the duration of the contract starting from the first induction training prior to commencement of work to reinforce the understanding of the project’s ESHS and OHS standards and the GBV and VAC Codes of Conduct.

I do hereby acknowledge that I have read the foregoing Contractor’s Code of Conduct, and on behalf of the Contractor agree to comply with the standards contained therein. I understand my role and responsibilities to support the project’s OHS and ESHS standards, and to prevent and respond to GBV and VAC.

I understand that any action inconsistent with this Contractor Code of Conduct or failure to act mandated by this Contractor Code of Conduct may result in disciplinary action.

Contractor Name:	Signature:
Name:	Title:

Date: _____

B. Individual Code of Conduct

1. Professional Behaviour:

As an employee, I am committed to maintaining a high standard of professional behaviour. I will conduct myself with honesty, integrity, and respect toward colleagues, supervisors, clients, and others associated with the company.

2. Equal Opportunity and Inclusion:

I understand and support the company's commitment to equal opportunity and diversity. I will treat all individuals with respect and dignity, regardless of race, ethnicity, gender, age, sexual orientation, disability, or any other protected characteristic.

3. Sexual Harassment and Gender-Based Violence:

I will not engage in any form of sexual harassment or gender-based violence. I will foster a safe and inclusive work environment by promoting mutual respect and reporting any incidents promptly through the established channels.

4. Work Environment:

I will contribute to maintaining a positive and cooperative work environment. I will refrain from engaging in any behaviour that may be disruptive, disrespectful, or harmful to others.

5. Confidentiality:

I understand the importance of maintaining confidentiality regarding sensitive information related to the company, its clients, and fellow employees. I will not disclose confidential information without proper authorization.

6. Compliance with Policies and Laws:

I will comply with all company policies and applicable local, state, and federal laws. This includes, but is not limited to, safety regulations, anti-discrimination laws, and ethical standards.

7. Reporting Concerns:

If I witness or experience any behaviour that goes against this Code of Conduct, I am committed to reporting it promptly. I understand that [Construction Company Name] has established confidential reporting mechanisms, and I will utilize them to address concerns.

8. Respect for Property:

I will respect and take care of company property, equipment, and resources. Any misuse or damage will be reported promptly, and I will follow proper procedures for reporting and resolving such incidents.

9. Continuous Learning:

I am committed to continuous learning and professional development. I will actively participate in training programs provided by the company to enhance my skills and knowledge.

10. Social Responsibility:

I acknowledge my role in promoting a positive image of the company in the community. I will represent the company ethically and responsibly in all interactions outside the workplace.

By adhering to this Code of Conduct, I contribute to fostering a workplace environment that values professionalism, equality, and respect for all. I understand that any violation of this Code may result in disciplinary action, up to and including termination of employment

Contractor Name:	Signature:
Name:	Title:

Date: _____

APPENDIX 2: CHANCE FINDS PROCEDURE

Chance find procedures will be used as follows:

- a) Stop the project activities in the area of the chance find;
- b) Delineate the discovered site or area;
- c) Secure the site to prevent any damage or loss of removable objects. In cases of removable antiquities or sensitive remains, a night guard shall be deployed until the responsible local authorities and the DoMM take over;
- d) Notify the project supervisor who in turn will notify the responsible local authorities and the National Museum immediately (within 24 hours or less);
- e) The local authorities and the National Museum will take charge of protecting and preserving the site in case the finds are of interest to the Department.
 - i. This would require a preliminary evaluation of the findings to be performed by the archaeologists of the National Museum (within 72 hours). The significance and importance of the findings should be assessed according to the various criteria relevant to cultural heritage; those include the aesthetic, historic, scientific or research, social and economic values;
 - ii. Decisions on how to handle the finding shall be taken by the responsible authorities and the National Museum. This could include changes in the layout (such as when finding an irremovable remain of cultural or archaeological importance) conservation, preservation, restoration and salvage;
 - iii. The local authority/ National Museum decision concerning the management of the finding shall be communicated in writing by the National Museum; and
 - iv. Findings will be recorded in World Bank Implementation Supervision Reports (ISRs), and Implementation Completion Reports (ICRs) will assess the overall effectiveness of the project’s cultural property mitigation, management, and activities, as appropriate.
 - v. Project works could resume after permission is given from the responsible local authorities and the National Museum concerning safeguard of the heritage;
- f) The above procedure when applicable must be referred to as standard provisions during the project activities and therefore site supervisors shall monitor the procedure for any chance find encountered during project activities.

- g) If the finds are not of interest to the Department of Museums and Monuments, they should be reburied on a site set aside for such purpose and project works continue.

In case of Chance finds, the Implementing partners for the project will ensure that the chance finds procedure is adequately utilised and monitored.